

Fitting Instructions

Scan for the digital version of the fitting instructions.

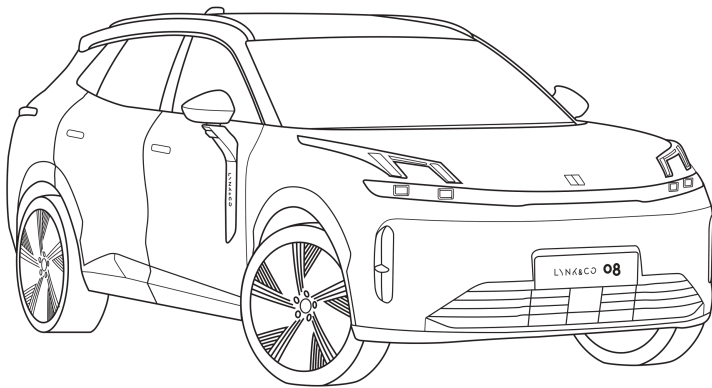

08

Lynk & Co

Product number:	40686
D-value:	9.73 kN
Max. vertical load	64kg
CM-Load:	64kg
EC type approval no.:	E11 55R 0313196
Type:	Fixed
Model year:	06/2025 ->

BRiNK[®]

Your perfect fit
brink.eu

Safety

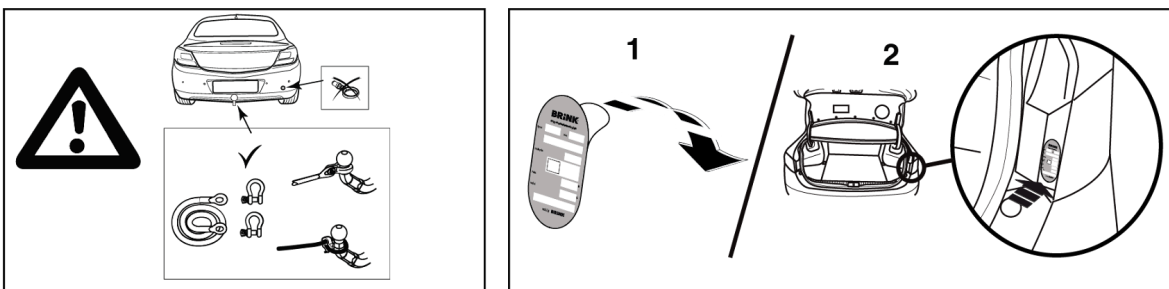
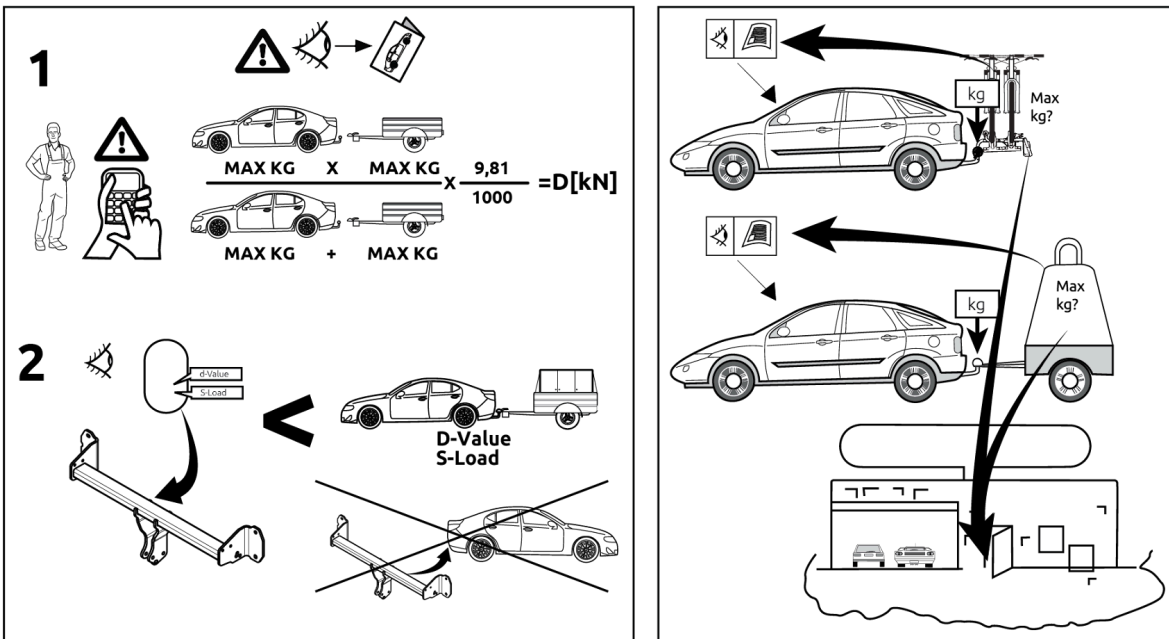
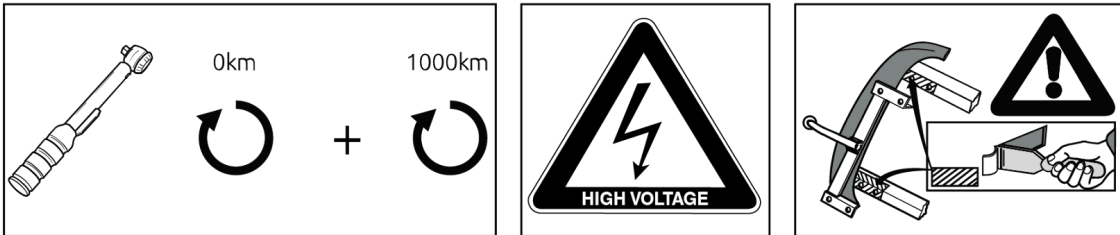
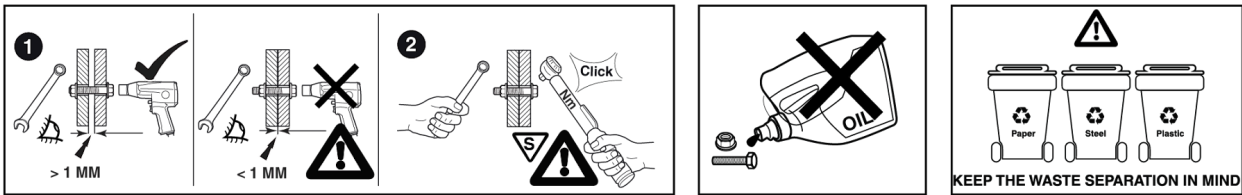

Important

Fitting in a HV electric car or hybrid vehicle must only be done by qualified personnel. The required qualifications may vary depending on the region. Please observe the local

legislation and legal directives relating to service to electric vehicles. Disregarding these instructions may lead to serious injuries or death.

Should this installation process entail the cutting of the bumper – conformation MUST be obtained by the installation engineer of the customer's acceptance

prior to completion. Brink Towing Systems do not accept responsibility for any matters arising as a result of this miscommunication.

The dealer should be consulted for possible necessary adjustment(s) of the vehicle".

Consult your dealer for the maximum tolerated pull weight and ball hitch pressure of your vehicle.

Remove the insulating material from the contact area of the fitting points. Do not drill through electrical-, brake- or fuellines.

Remove (if present) the plastic caps from the spot welding nuts.

Brink is not liable for damage caused directly or indirectly by incorrect assembly, including the use of unsuitable tools, the use of other assembly

methods and means than the ones outlined, and the incorrect interpretation of these assembly instructions.

After approximately 1000 km of trailer use, retighten

all bolts to the correct torque values.

This fitting instruction has to be enclosed in the vehicle documents afterfitting the towbar.

All measurements are in mm!

Sketch

Washers



Contact-lock Washer

Bolts/Nuts



10.9



10

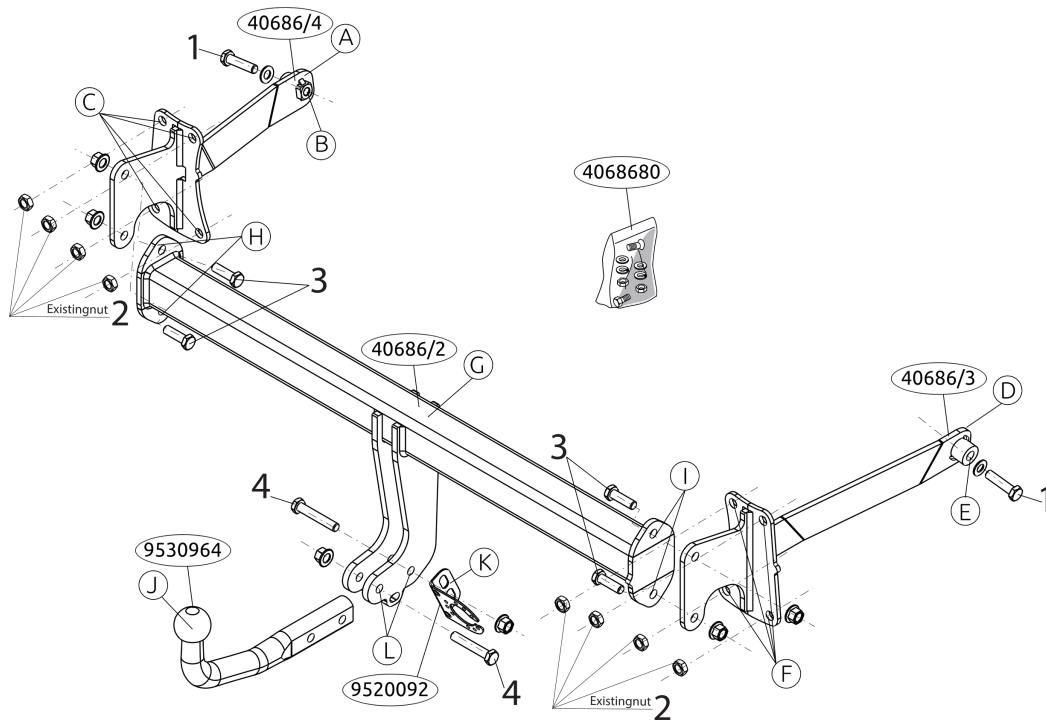

Torque

Before you start the fitting you must check the type plate to determine which sketch, in the fitting instruction, is applicable.

1. M12x50 (10.9)

*****M* E: 75 Nm

*****M* P: 75 Nm

2. Existing nuts

*****M* E: 45 Nm

*****M* P: 45 Nm

3. M12x40 (10.9)

*****M* E: 120 Nm

*****M* P: 105 Nm

4. M12x70 (10.9)

*****M* E: 120 Nm

*****M* P: 105 Nm

Fitting Instructions

1. Remove the bumper and the buffer beam from the vehicle. The buffer beam will no longer be needed. See image 1.
2. Fit side plate A at points B and C, hand-tight.
3. Fit side plate D at points E and F, hand-tight.
4. Fit the cross beam G between supports A and D at points H and I and fit the whole thing finger-tight.
5. Tighten all nuts and bolts to the torque indicated in the drawing.
6. Saw out the indicated section in accordance with image 2.
7. Replace the items removed in step 1.
8. Fit the ball hitch J , including socket plate K at points L.
9. Tighten all nuts and bolts to the torque indicated in the table.

For dismantling and fitting the vehicle parts, see the site handbook. For fitting instructions and attachment method, see drawing.

Images

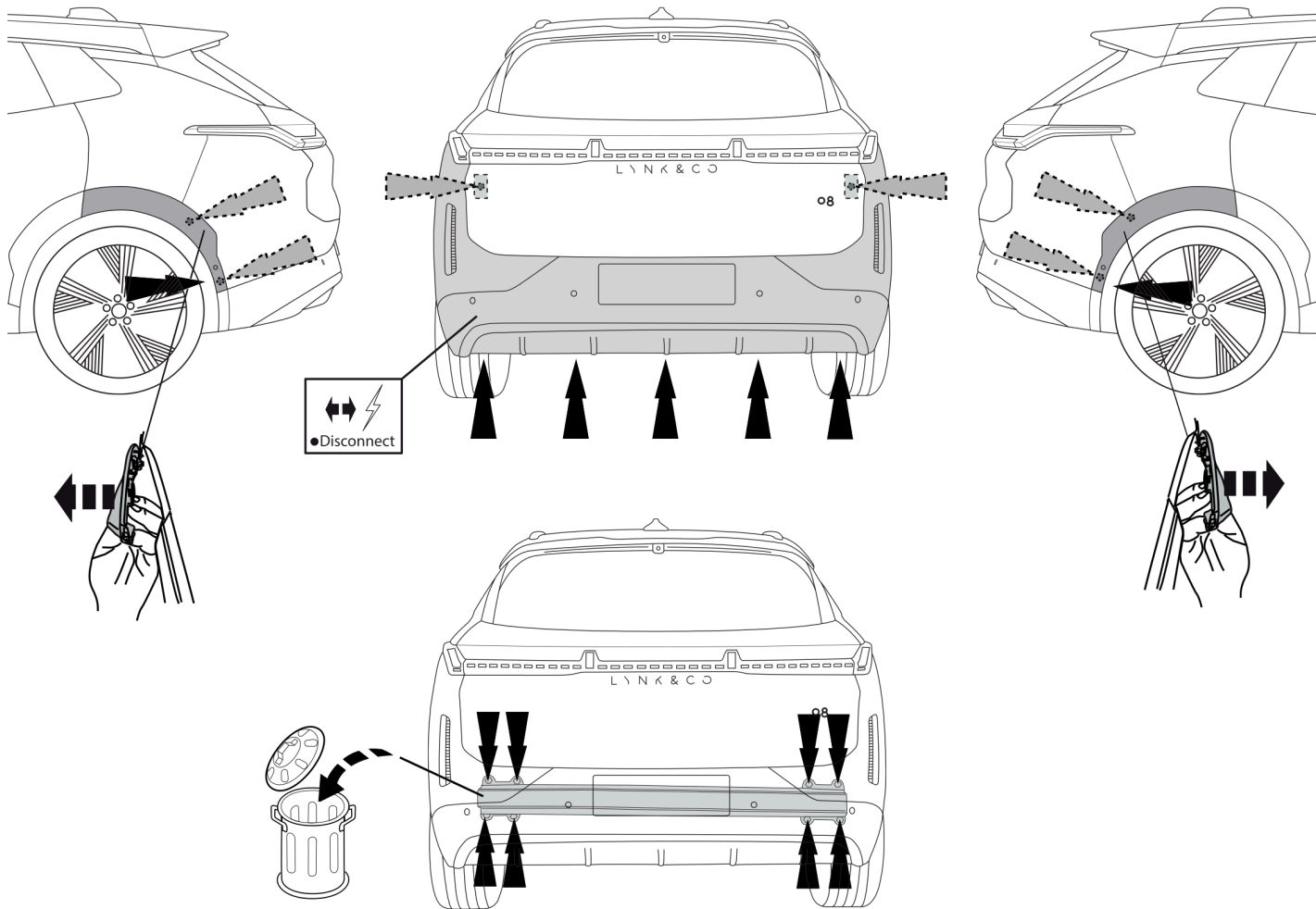

Img. 1

Lynk & Co 08

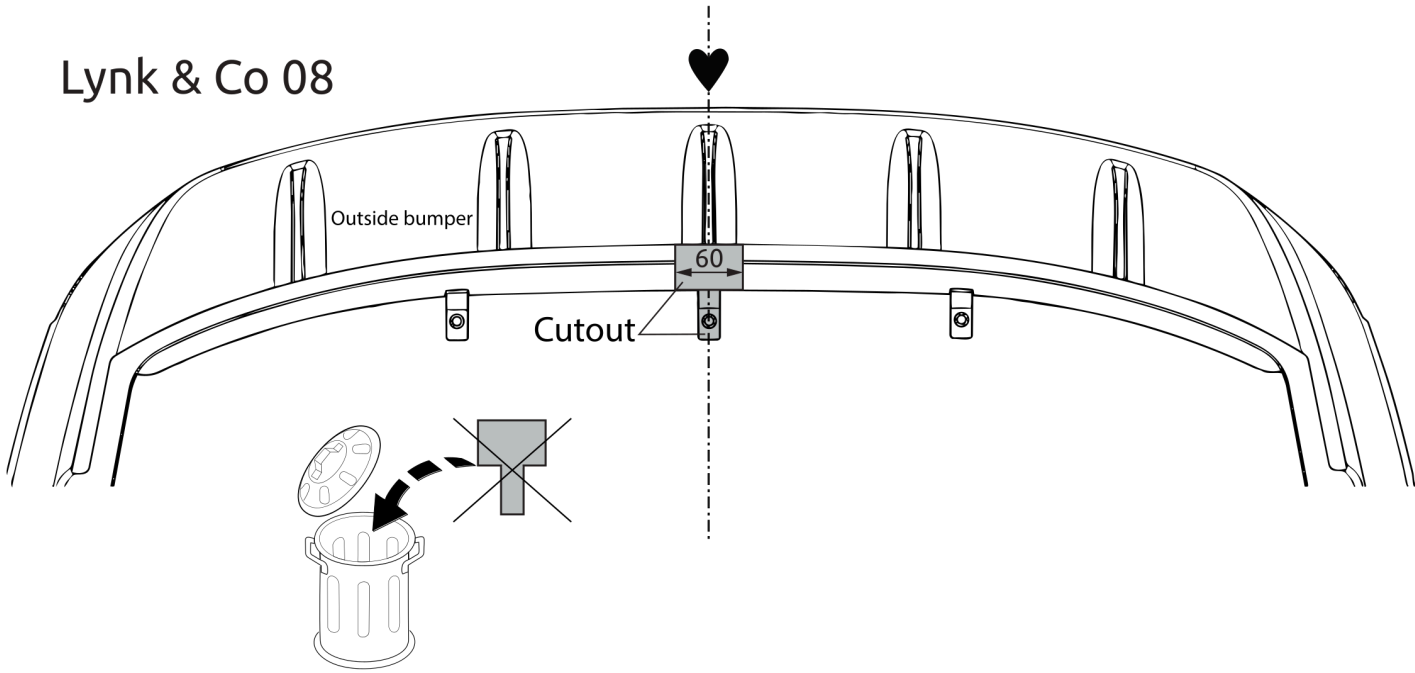

Img. 2