

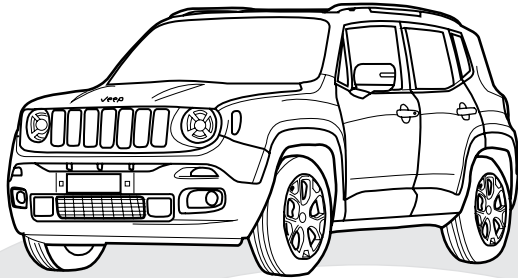

# Jeep Renegade Phase I (type BU)

10/'14 - 09/'18

✓ PLUG-IN HYBRIDE (PHEV)



# Fiat 500X (type 334)

09/'14 -

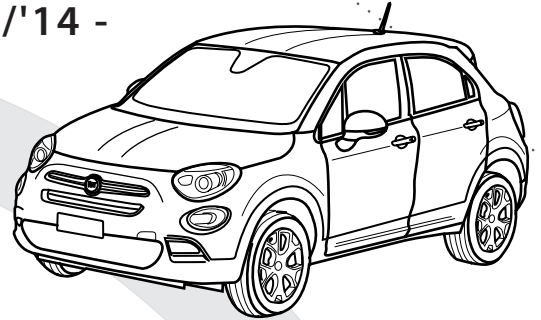

# Fiat 500X Cross + FL

09/'14 -

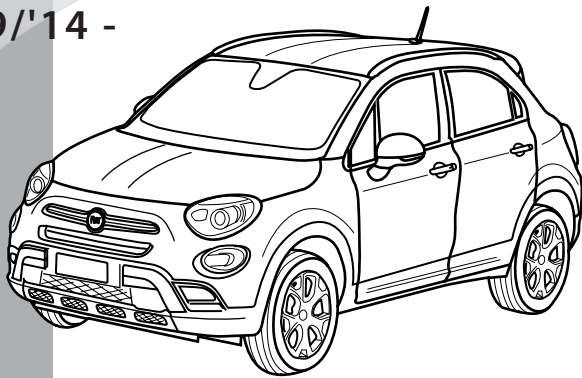

# Fiat Tipo 4D (type 356)

10/'15-

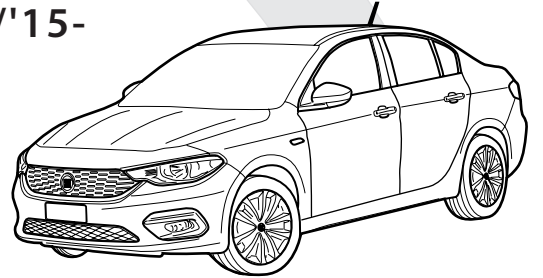

# Fiat Tipo 5D (type 357)

03/'16-

✗ SPORT

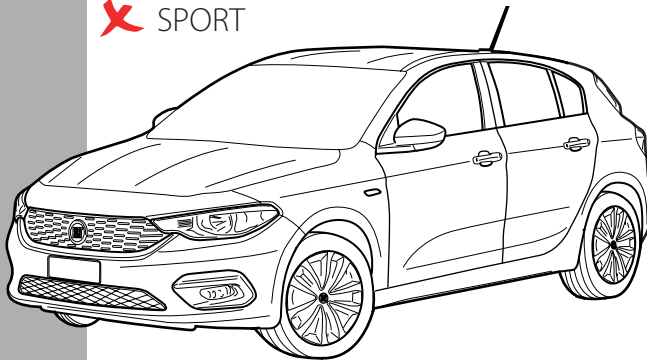

# Jeep Renegade

## Phase II (type BU)

10/'18 -

✓ PLUG-IN HYBRIDE (PHEV)

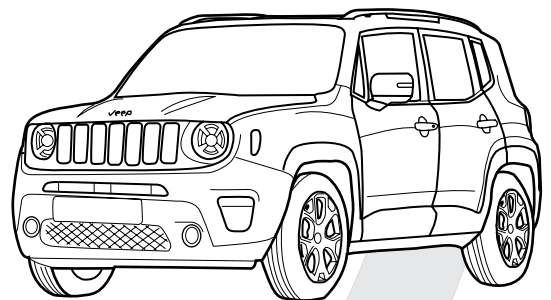

# Fiat 500X Sport ✓ HYBRIDE

## + Fiat 500X Urban

'19 -

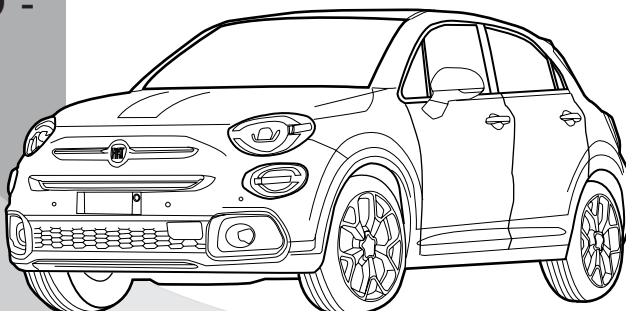

# Fiat Tipo Cross

01/'21-

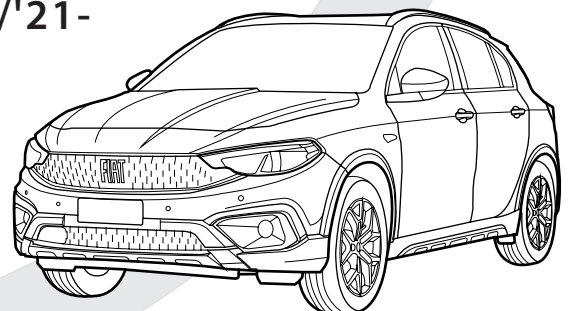

## NL Belangrijke raadgevingen

### Montage

- Voor de montage moet de trekhaak eerst op het voertuig gepresenteerd worden.

De belasting van een aanhangwagen en van een accessoire dat op de koppelingskogel wordt voorzien, zijn anders van aard. Voor beiden kunnen verschillende limieten van toepassing zijn. Hiervoor verwijzen we naar het instructieboekje van de wagen of naar uw concessiehouder.

## FR Recommandations importantes

### Montage

- Présenter l'attelage sous le véhicule avant d'effectuer le montage.

La charge d'une remorque ou d'un accessoire prévue sur la boule d'attelage, est de nature diverse. Pour ces deux éléments, il peut y avoir des limites d'utilisation. Nous vous recommandons de vous référer à votre livret d'instructions ou de vous renseigner chez votre concessionnaire.

## GB General instructions

### Fitting

- Present the towbar under the car first to check if all points are right.

The load of a trailer and of an accessory fitted on the towing ball are of a different nature. Different limits may apply to both. For this matter, we refer to the instruction manual of the vehicle or we advise you to contact your concessionaire.

## D Wichtige ratschläge

### Montage

- Erst die Anhängerkupplung und das Fahrzeug kontrollieren, danach montieren.

Die Belastung eines Anhängers und eines Zubehörs, die man auf einer Kupplungskugel voraussieht, ist wesentlich anders. Für beide gilt, dass diese unterschiedlich begrenzt sein können. Deswegen möchten wir verweisen auf die Bedienungsanleitung des Fahrzeugs oder auf Ihren Vertragshändler.

## E Instrucciones generales

### Montaje

- Presentar el enganche debajo del vehículo antes de realizar el montaje.

La carga de un remolque y un accesorio montado en una bola de remolque son de una naturaleza diferente. Se pueden aplicar diferentes límites a ambos. Para este asunto, nos referimos al manual de instrucciones del vehículo o le recomendamos que contacte a su distribuidor.

## DK Generelle instruktioner

### Montering

- Præsenter trækstangen under bilen først for at kontrollere, om alle punkter er rigtige.

Belastningen af en trailer og af tilbehør tilkoblet anhængertrækket er forskellige. Der kan være forskellige begrænsninger på begge. I disse tilfælde henviser vi til bilens manual, eller anbefaler dig at kontakte bilforhandleren

## IT Consigli importanti

### Montaggio

- In primo luogo, presentare la struttura sotto l'automobile per verificare che tutti i punti di attacco coincidano.

La massa rimorchiabile del veicolo potrebbe essere diversa dal valore riportato sul documento del gancio di traino. Per questo motivo, vi invitiamo a consultare sempre la carta di circolazione del veicolo (Pos. O.1) o a rivolgervi alla vostro concessionario di fiducia

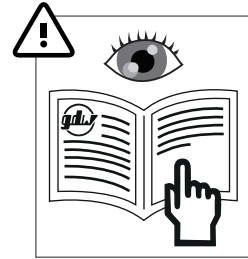
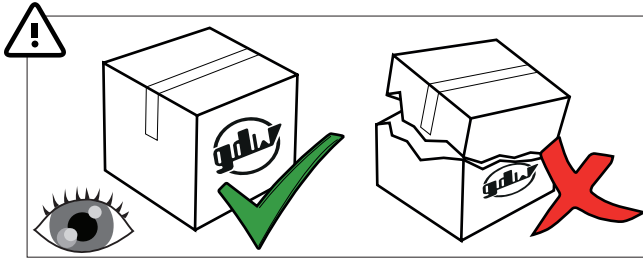

**gdw**  
+32 56 62 77 79  
helpdesk@gdwtowbars.com

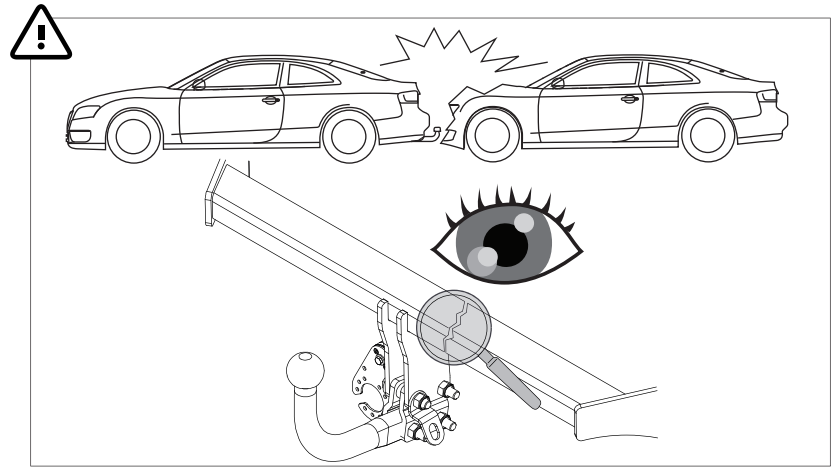
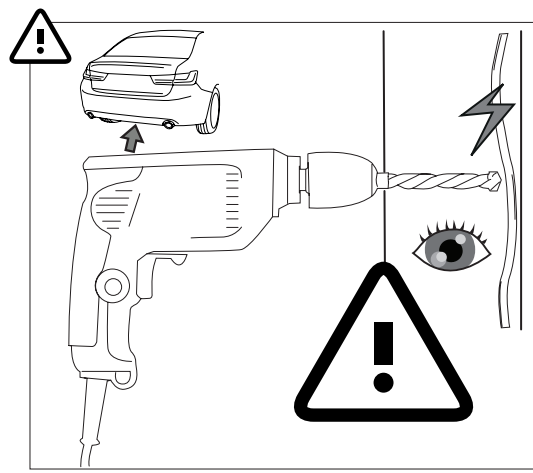

1000 km / 1 x per year

- 1
- 2
- 3

GREASE



1 - XXX - XXX

MADE BY  **D 9,95** **F** **E6**

BELGIUM **S 100** **55R-011618**

REF N° **2486** **SERIAL N° XXXX**







**DESCRIPTION**  
 Jeep Renegade Phase I / Fiat 500X /  
 Fiat 500X-Cross + FL / Fiat Tipo 4D / Fiat Tipo 5D / Tipo Cross/  
 Jeep Renegade Phase II / Fiat 500X Sport / Fiat 500X Urban







 



$D = \frac{\text{max kg} \times \text{max kg}}{\text{max kg} + \text{max kg}} \times 0.00981 \leq 9,95 \text{ kN}$

$S = \begin{cases} \leq 100 \text{ kg} \\ \leq 1800 \text{ kg} \end{cases}$

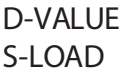
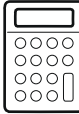
See the Certificate Of Conformity (COC) of your vehicle or contact your dealer to verify the max. trailer weight of your car!

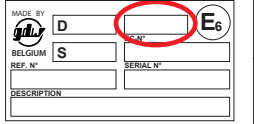
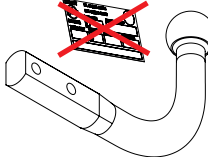
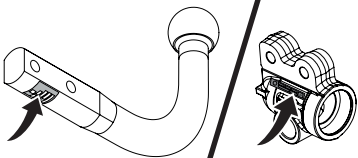

   **A50-X?**  

**19** **22** **13** **7** **TX30** **PH2** **PZ2**

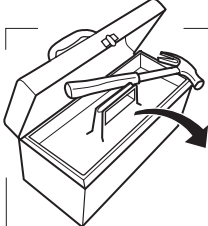
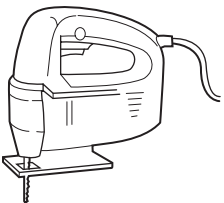
**JEEP RENEGADE ONLY** **Ø6**

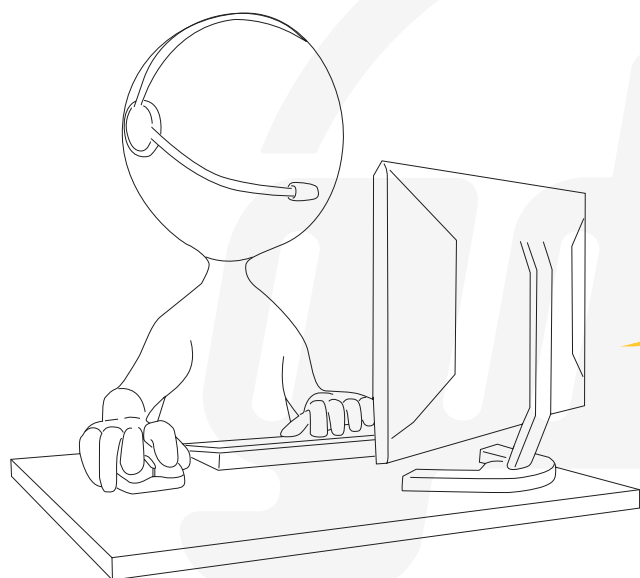

**helpdesk@gdwtowbars.com**  
**+32 56 62 77 79**

Monday	08:00 - 12:00	12:30 - 16:30
Tuesday	08:00 - 12:00	12:30 - 16:30
Wednesday	08:00 - 12:00	12:30 - 16:30
Thursday	08:00 - 12:00	12:30 - 16:30
Friday	08:00 - 12:00	12:30 - 15:30

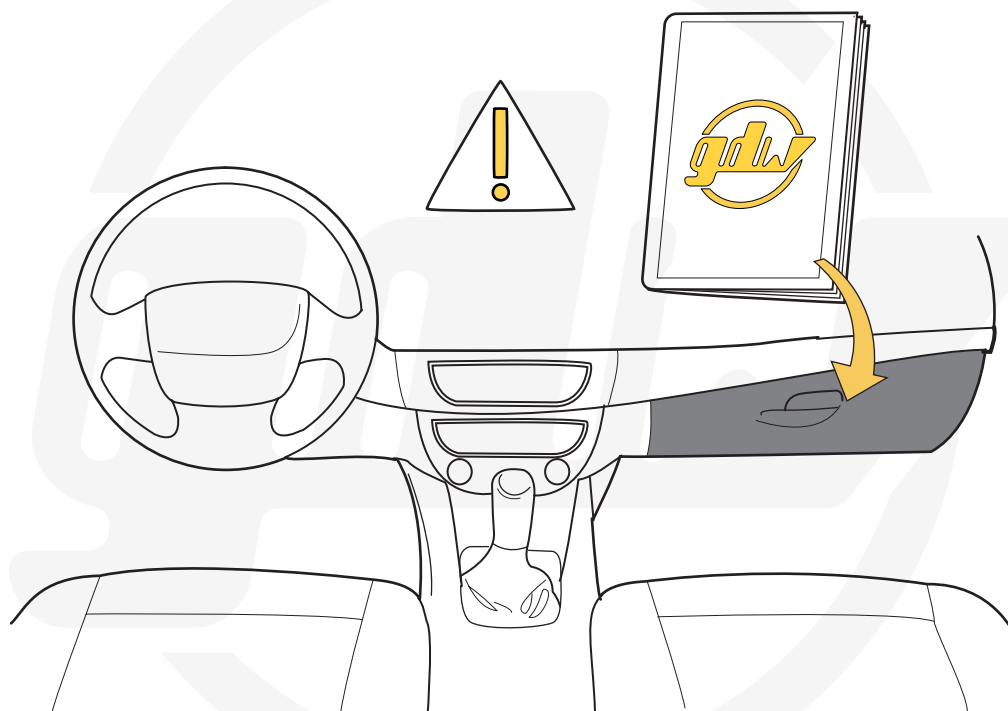

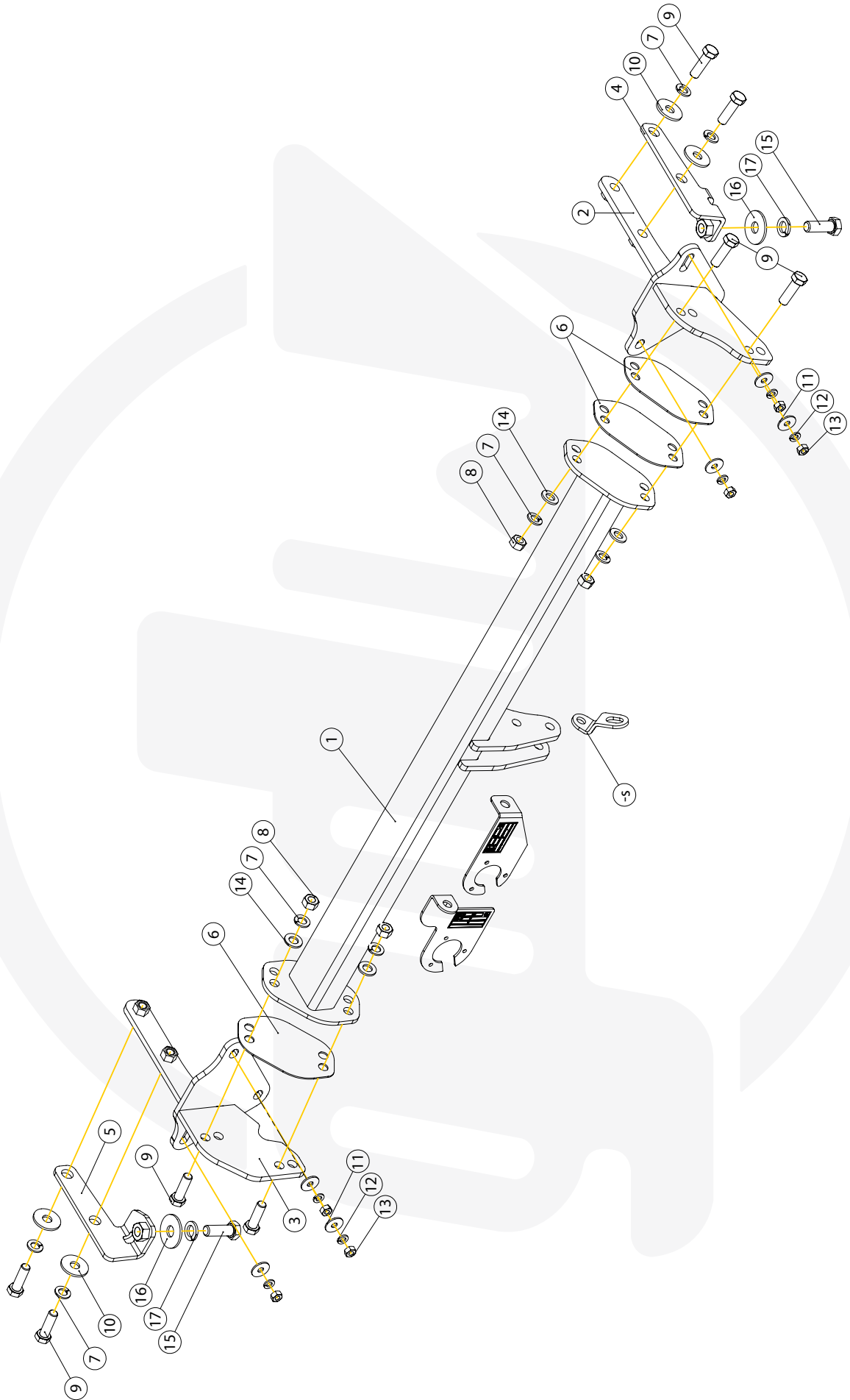



# Jeep Renegade Phase I

10/'14 - 09/'18

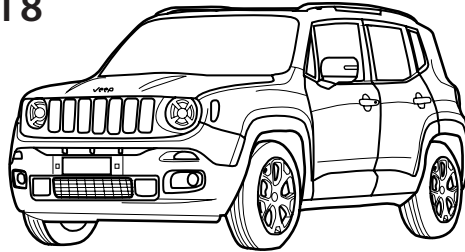

1	—	9
23	—	30
33	—	35
43	—	46

# Jeep Renegade Phase II

10/'18 -

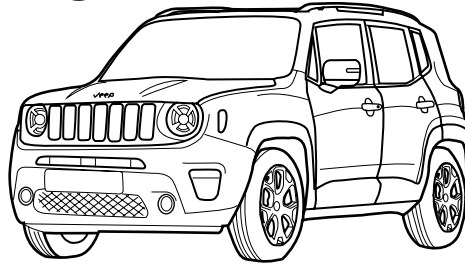

# Fiat 500X

'15 -

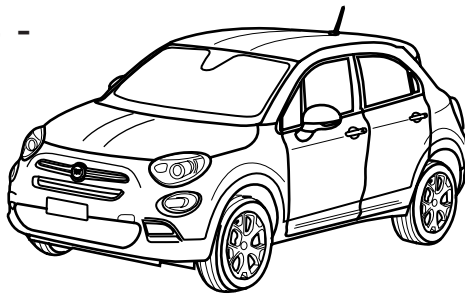

10	—	14
23	—	30
36		
43	—	44
47	—	48

# Fiat 500X-cross

'15 - '18

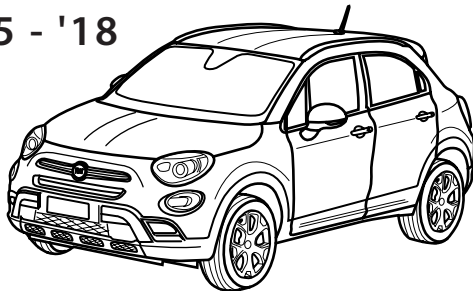

10	—	14
23	—	30
37		
43	—	44
47	—	48

# Fiat Tipo 4D

'16 -

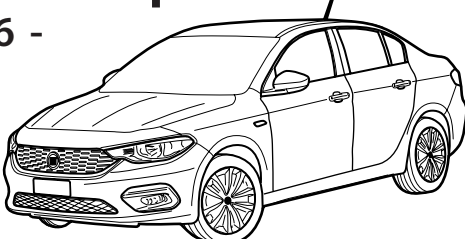

15	—	16
19	—	30
38		
43	—	44
47	—	48

## Fiat Tipo 5D

'16 -

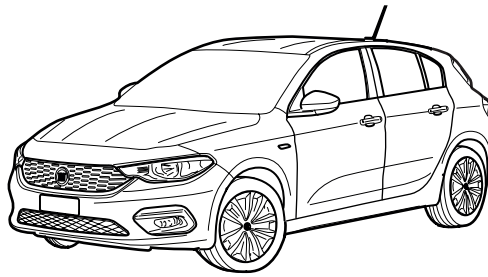

17	—	30
39		
43	—	44
47	—	48

## Fiat Tipo Cross

'21 -

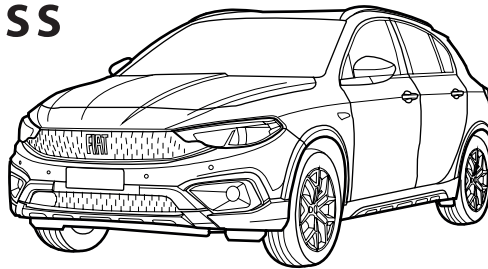

17	—	30
31	&	40
41	—	42
47	—	48

## Fiat 500X Cross Facelift

'19 -

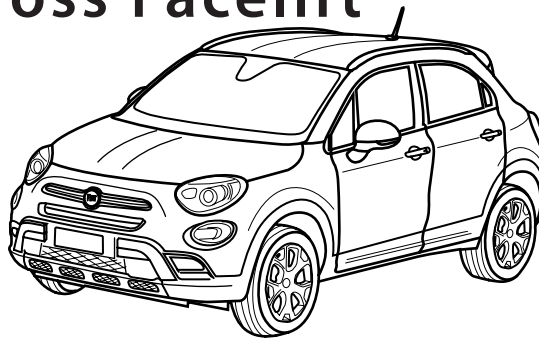

10	—	14
23	—	29
32	&	37
43	—	44
47	—	48

## Fiat 500X Urban

'19 -

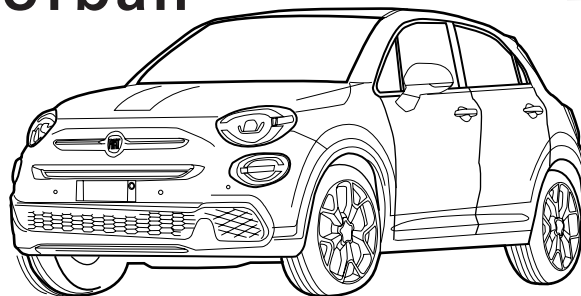

10	—	14
23	—	29
32	&	41
43	—	44
47	—	48

## Fiat 500X Sport

'19 -

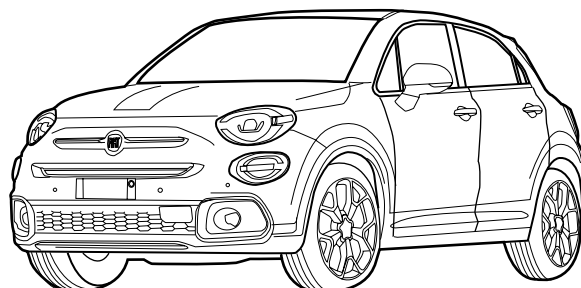

10	—	14
23	—	29
32	&	42
43	—	44
47	—	48

1

JEEP RENEGADE

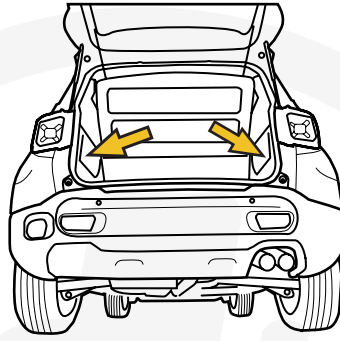

1

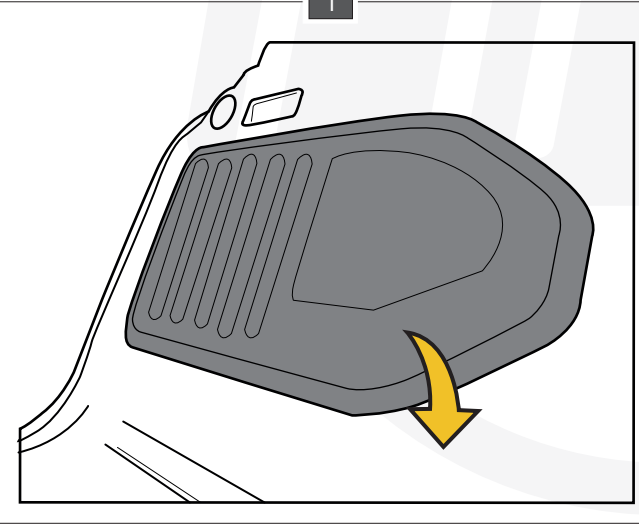

2

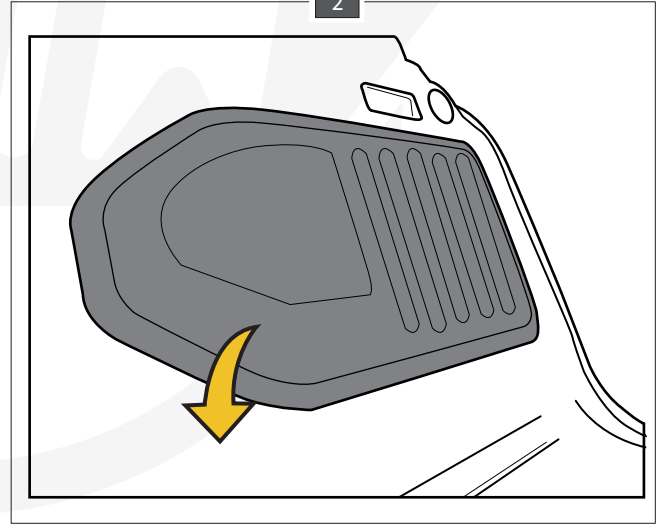

2

JEEP RENEGADE

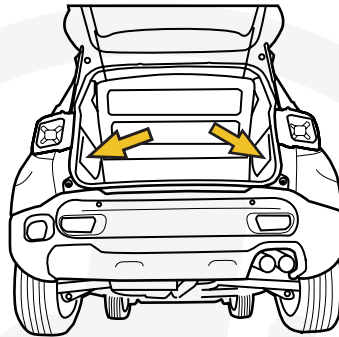

1

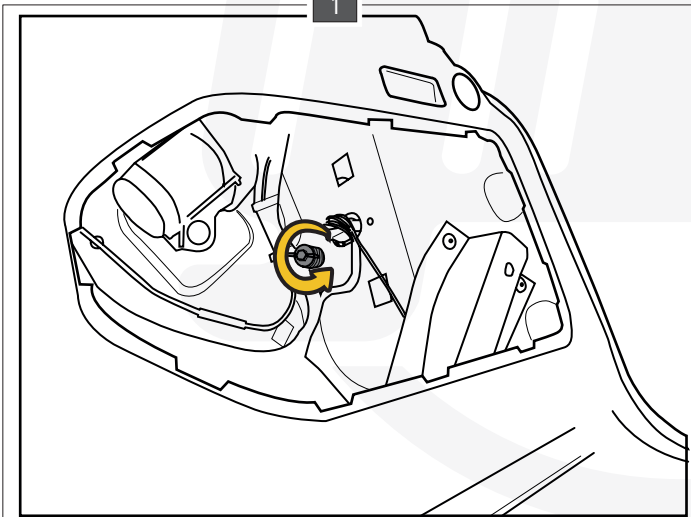

2

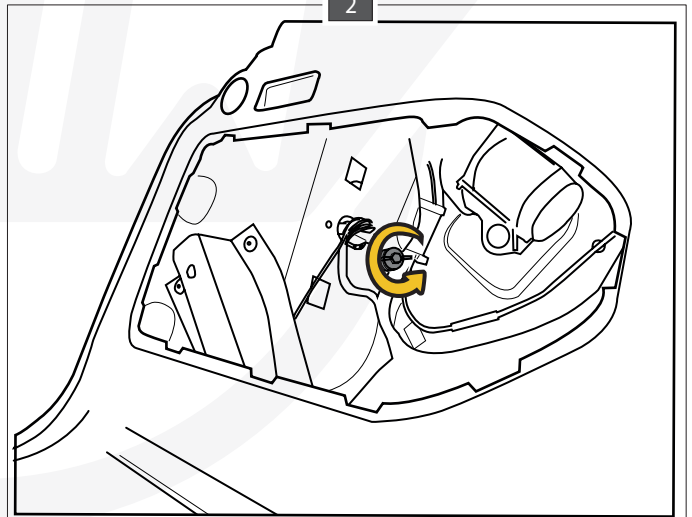

3 JEEP RENEGADE

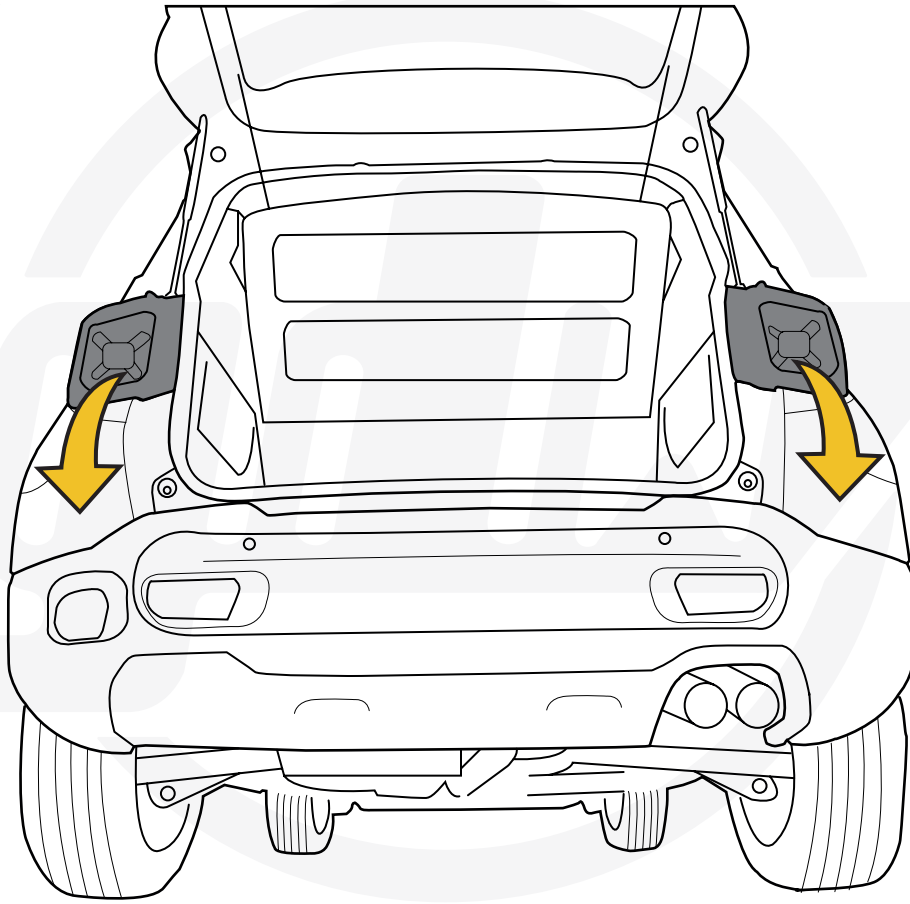

4 JEEP RENEGADE

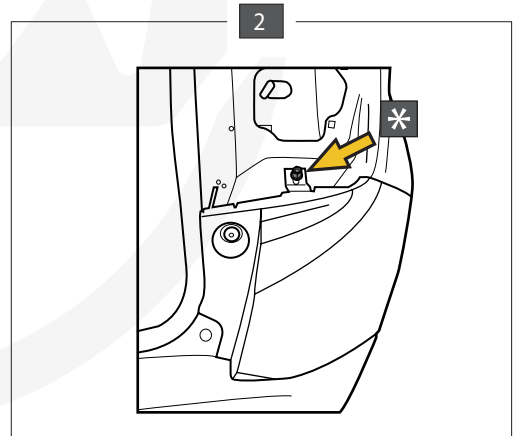
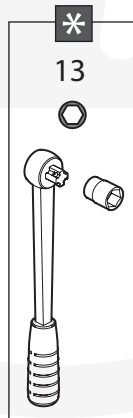
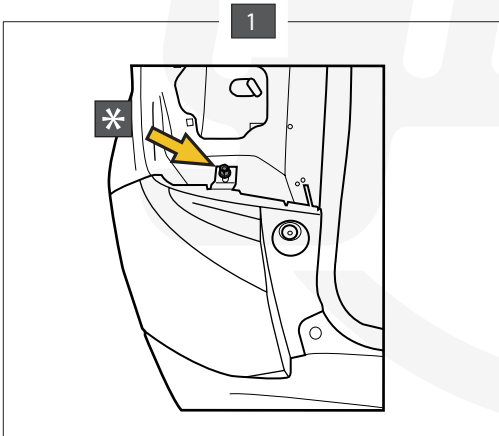
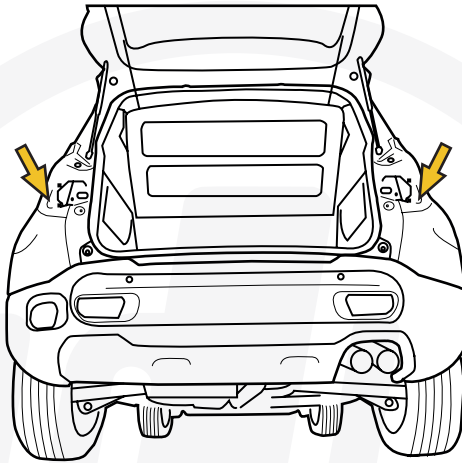

5 JEEP RENEGADE

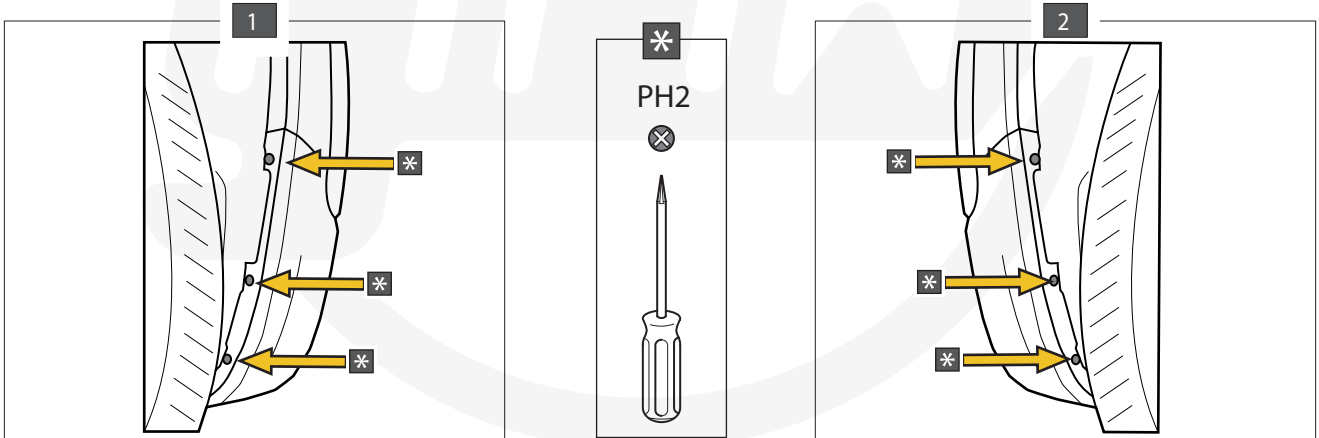
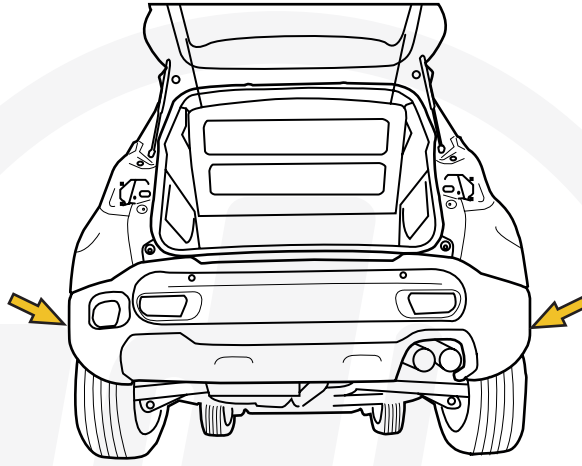

6 JEEP RENEGADE

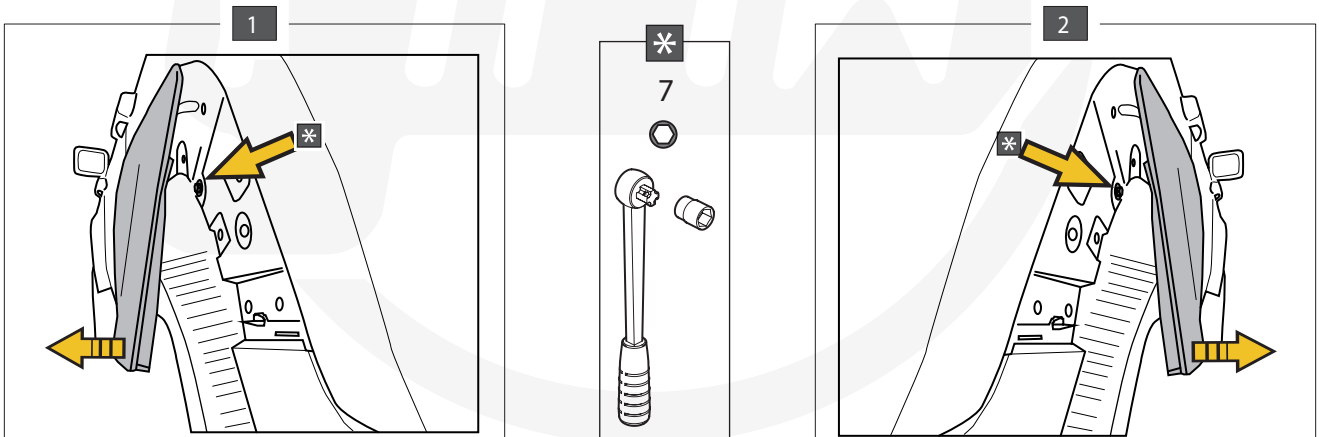
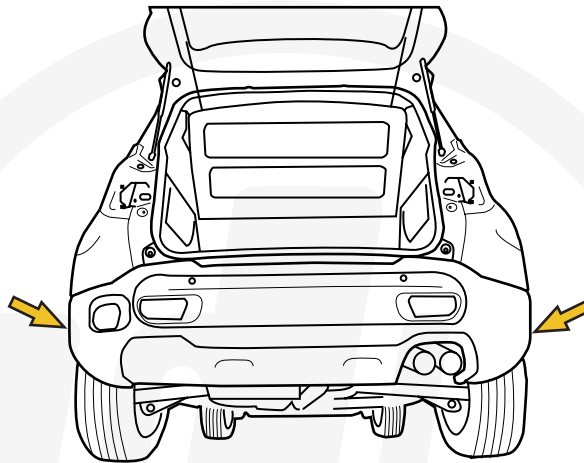

7 JEEP RENEGADE

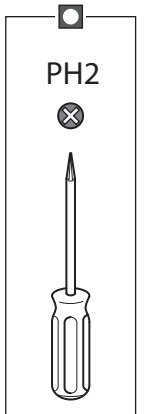
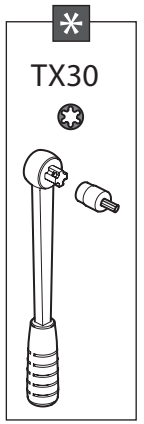
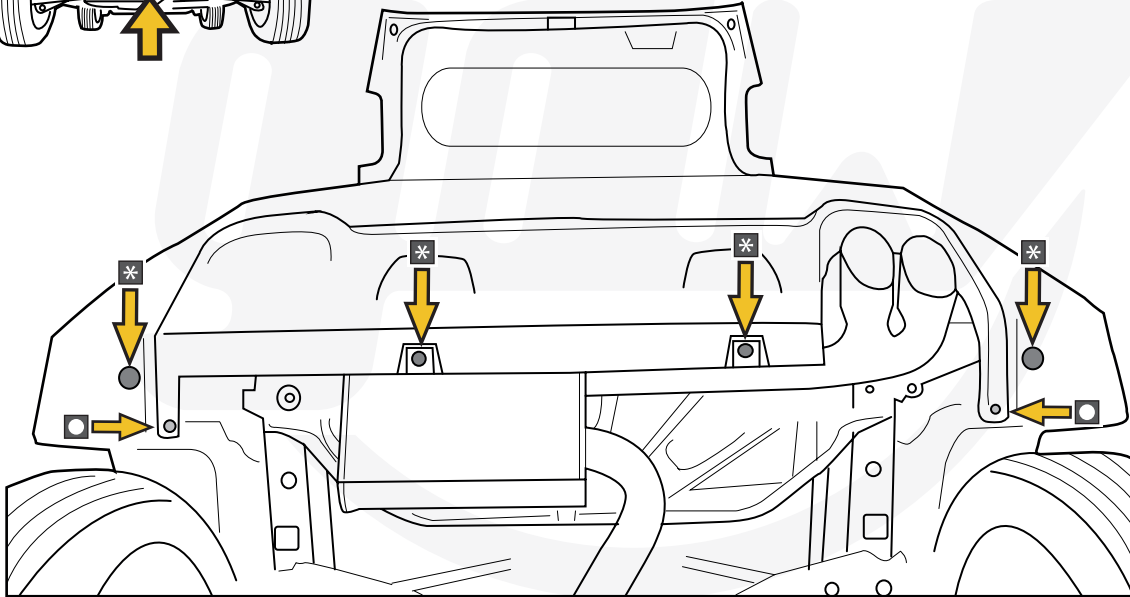
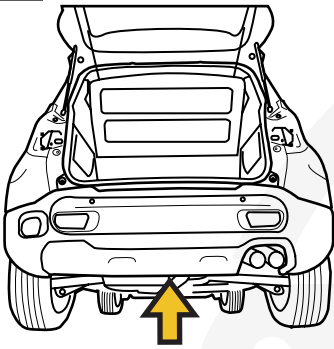

8 JEEP RENEGADE

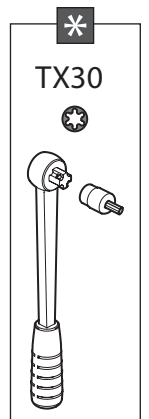
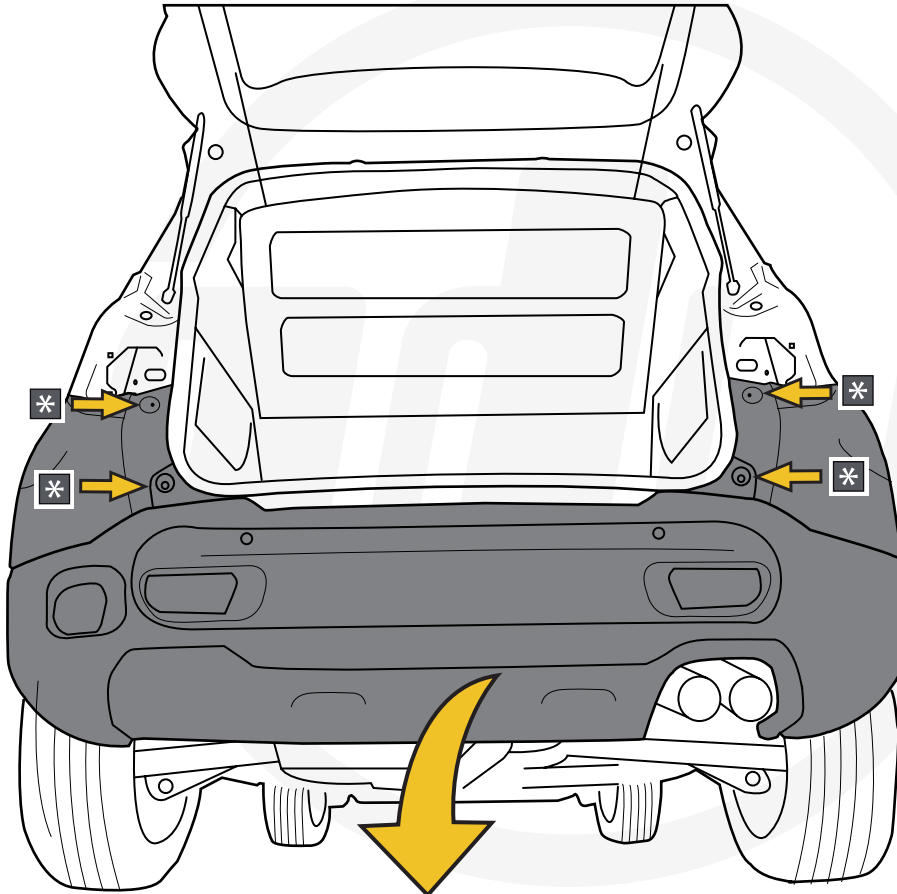

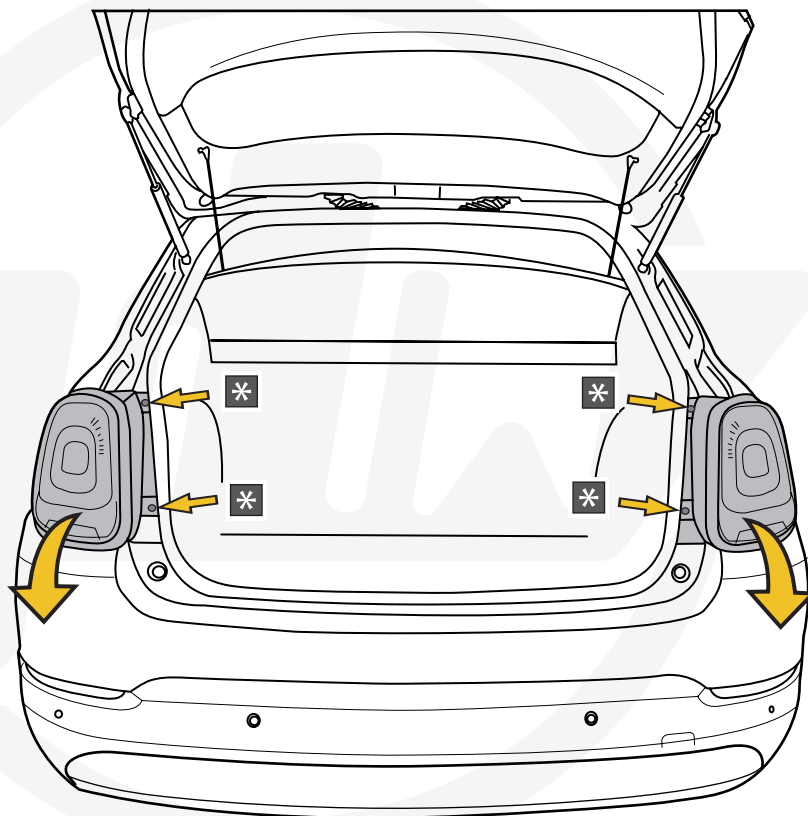
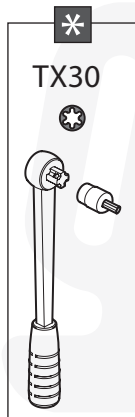
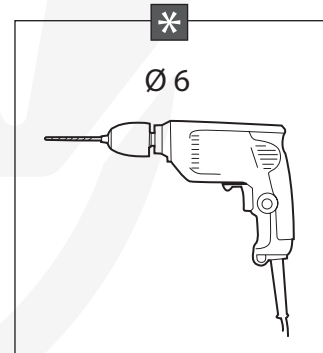
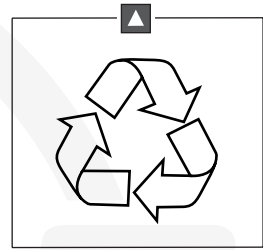
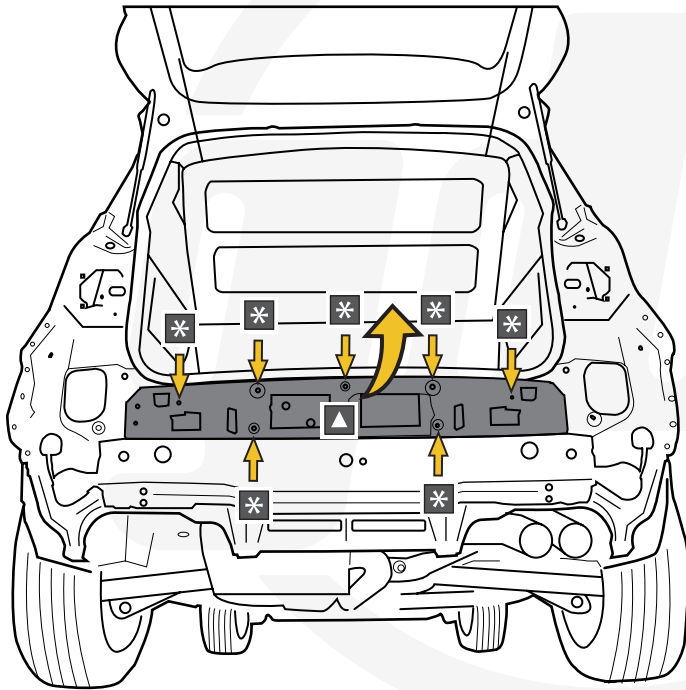

11 FIAT 500X / 500X-CROSS + FACELIFT + 500X URBAN + 500X SPORT

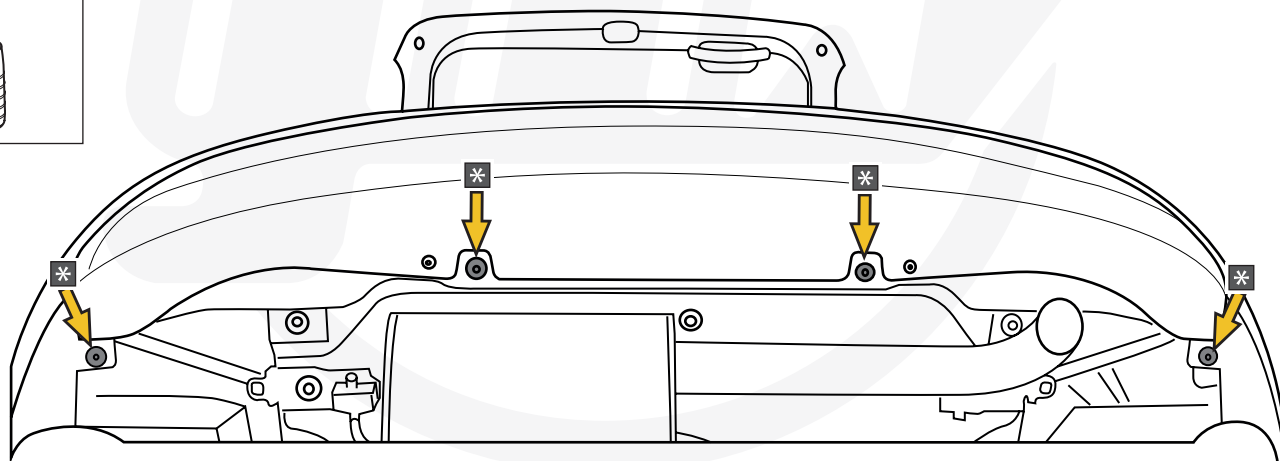
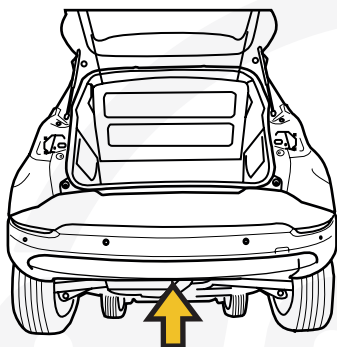
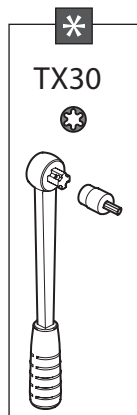

12 FIAT 500X / 500X-CROSS + FACELIFT + 500X URBAN + 500X SPORT

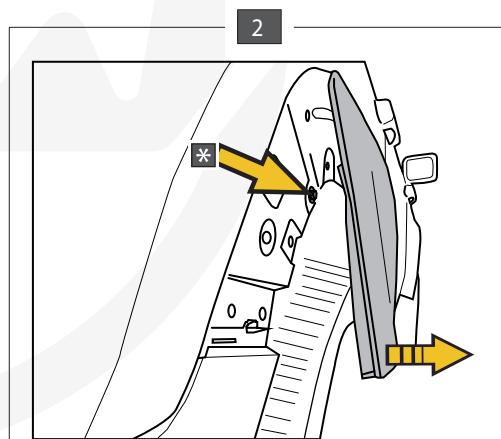
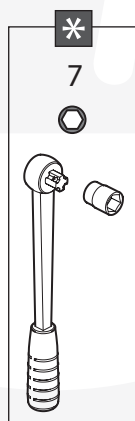
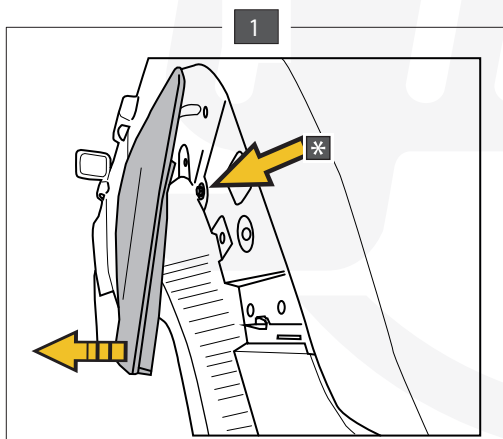
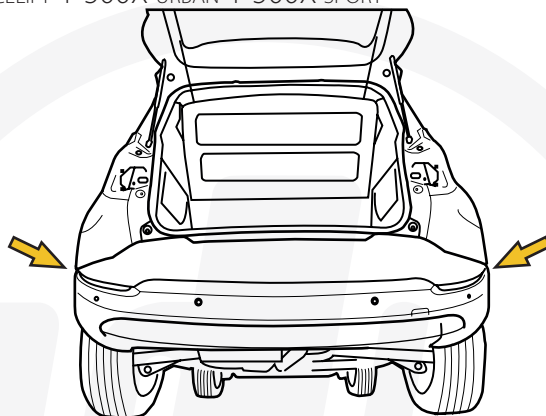

13 FIAT 500X / 500X-CROSS + FACELIFT +  
500X URBAN + 500X SPORT

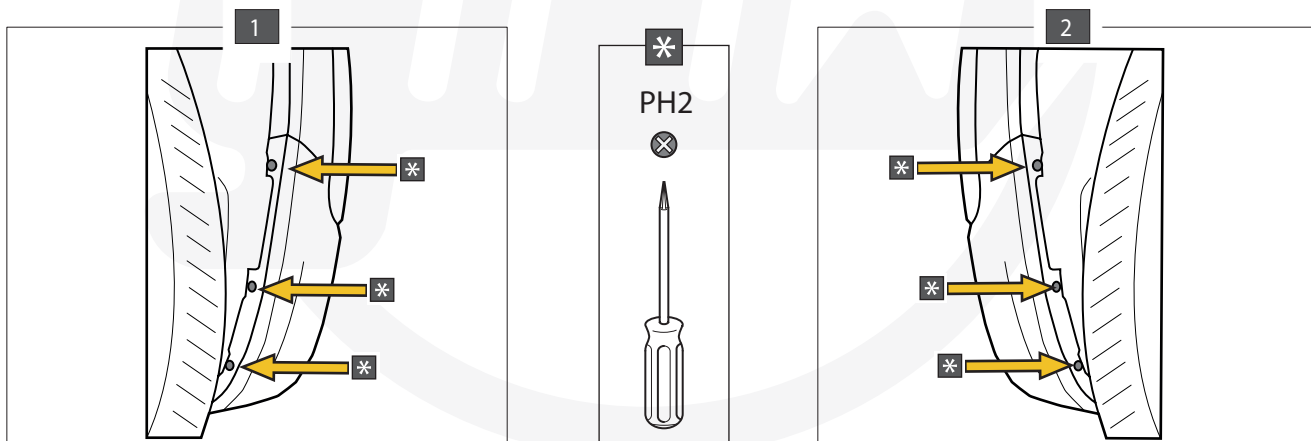
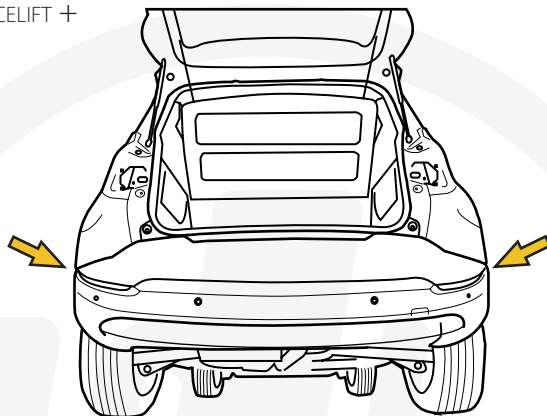

14 FIAT 500X / 500X-CROSS + FACELIFT + 500X URBAN + 500X SPORT

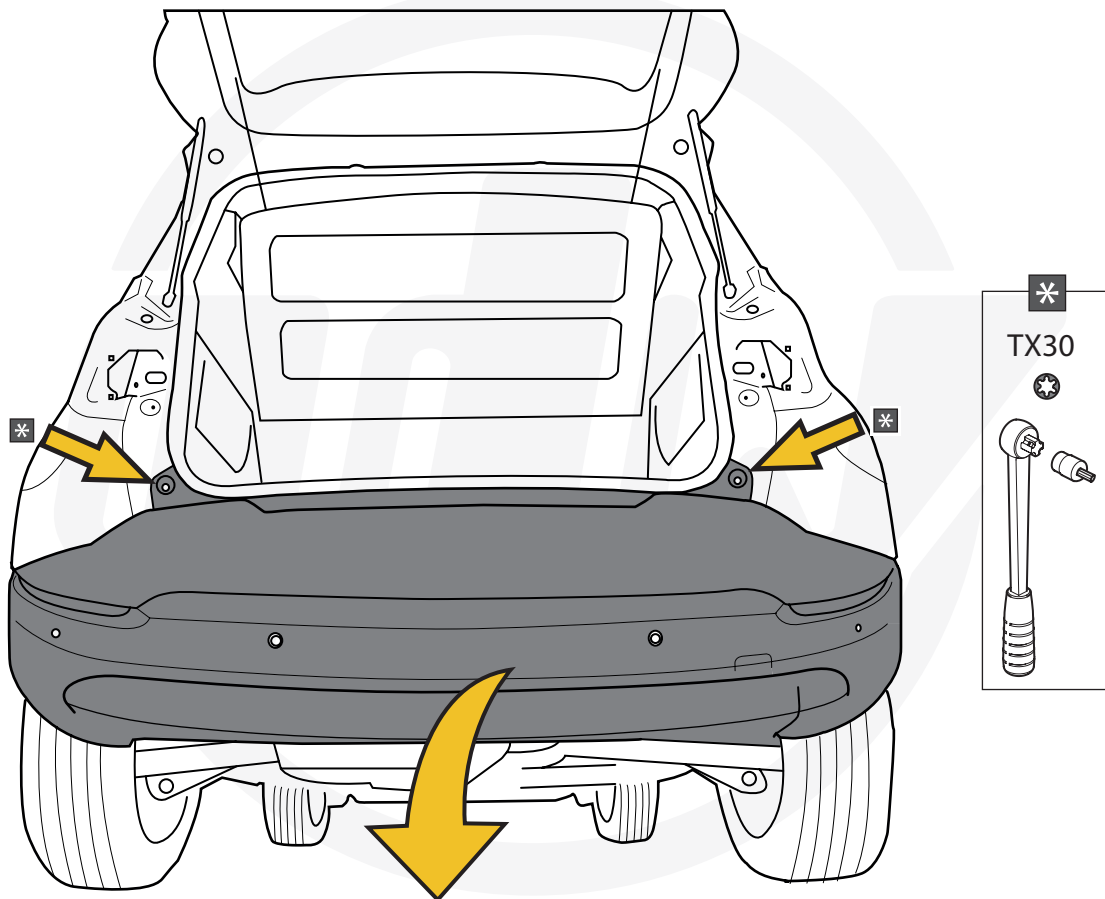

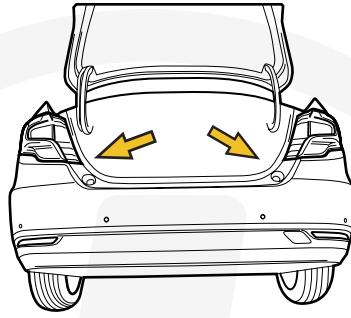

1

2

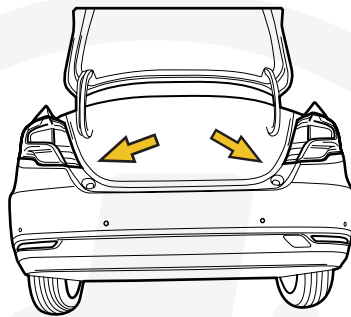
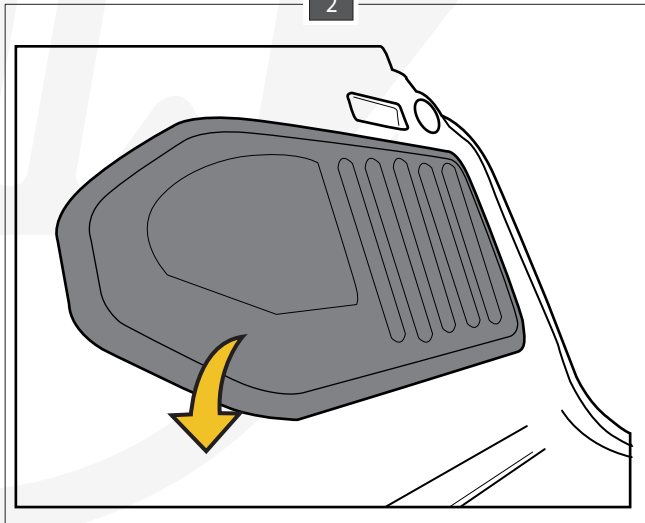
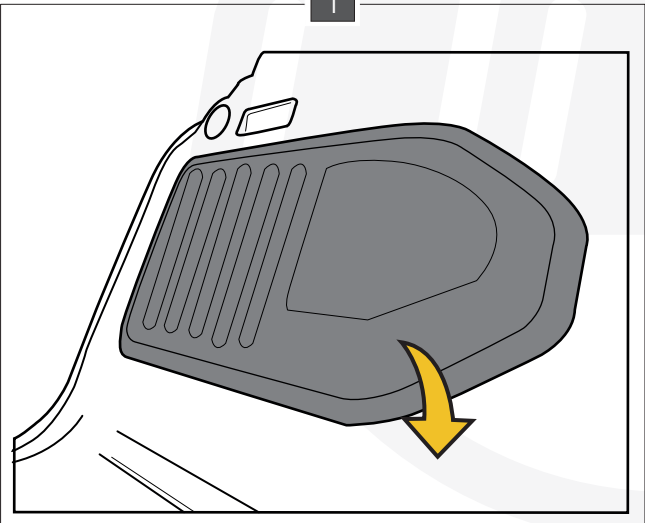

1

2

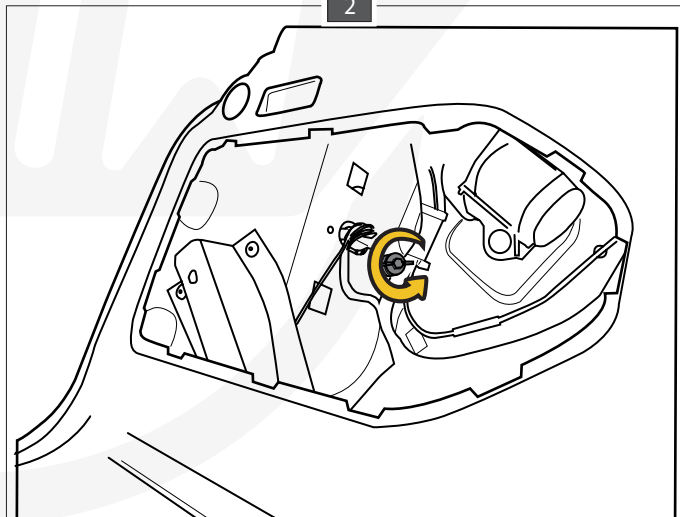
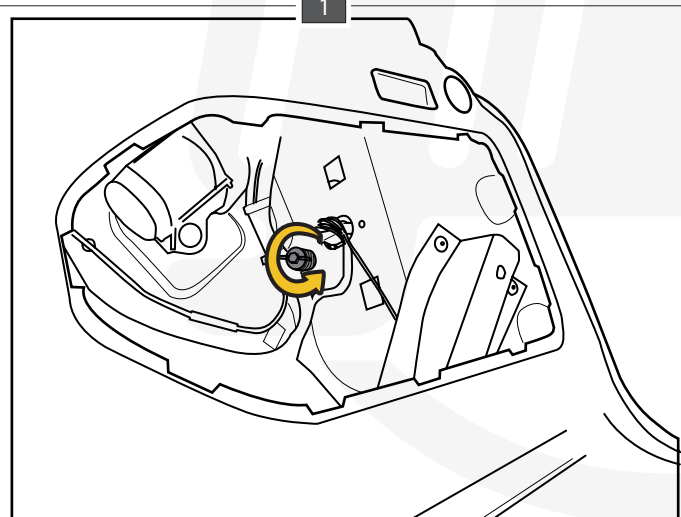

17 FIAT TIPO 5D + FIAT TIPO CROSS 21'-

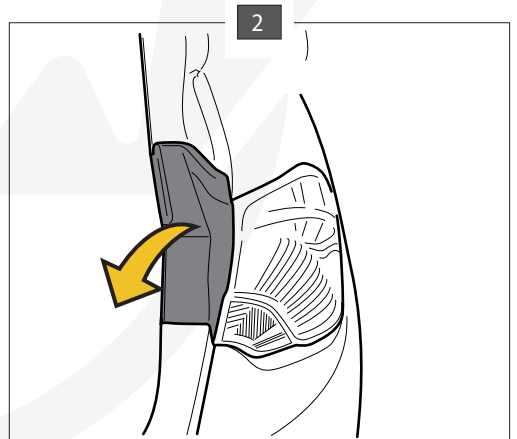
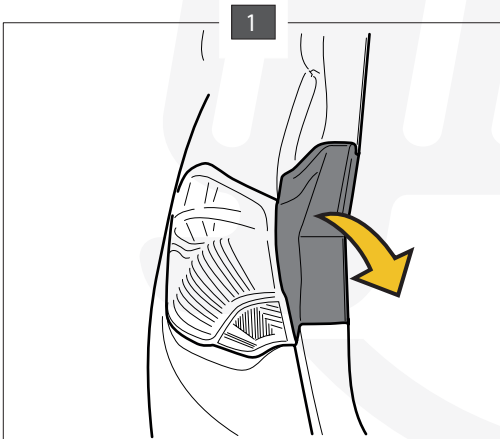
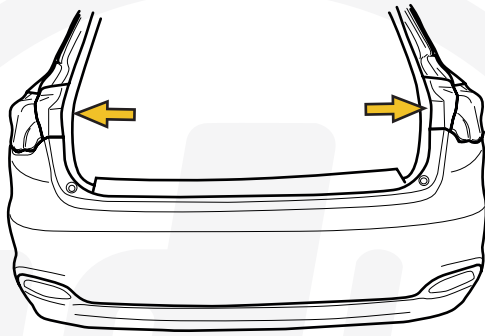

18 FIAT TIPO 5D + FIAT TIPO CROSS 21'-

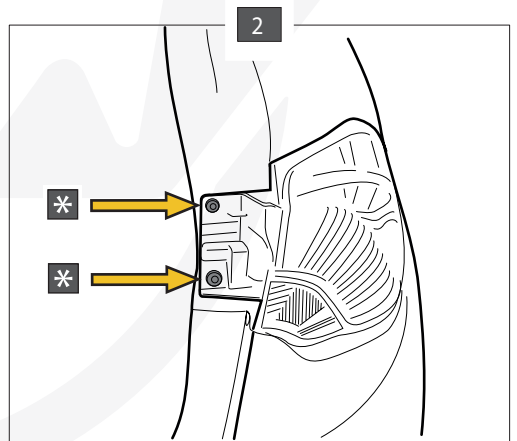
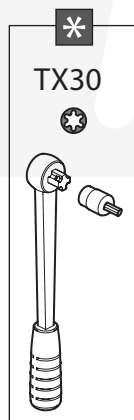
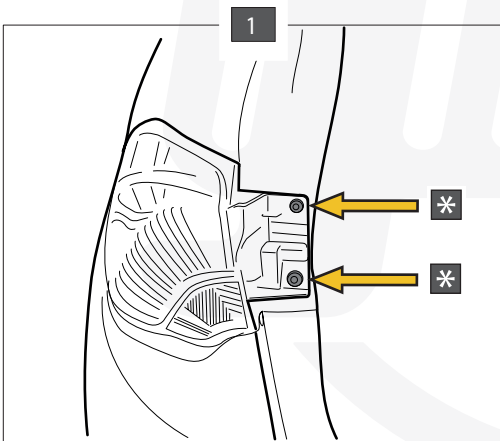
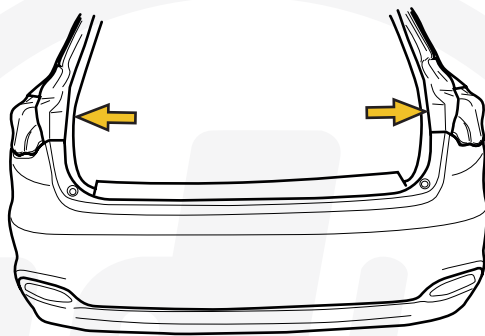

19 FIAT TIPO 4D + TIPO 5D  
+FIAT TIPO CROSS '21-

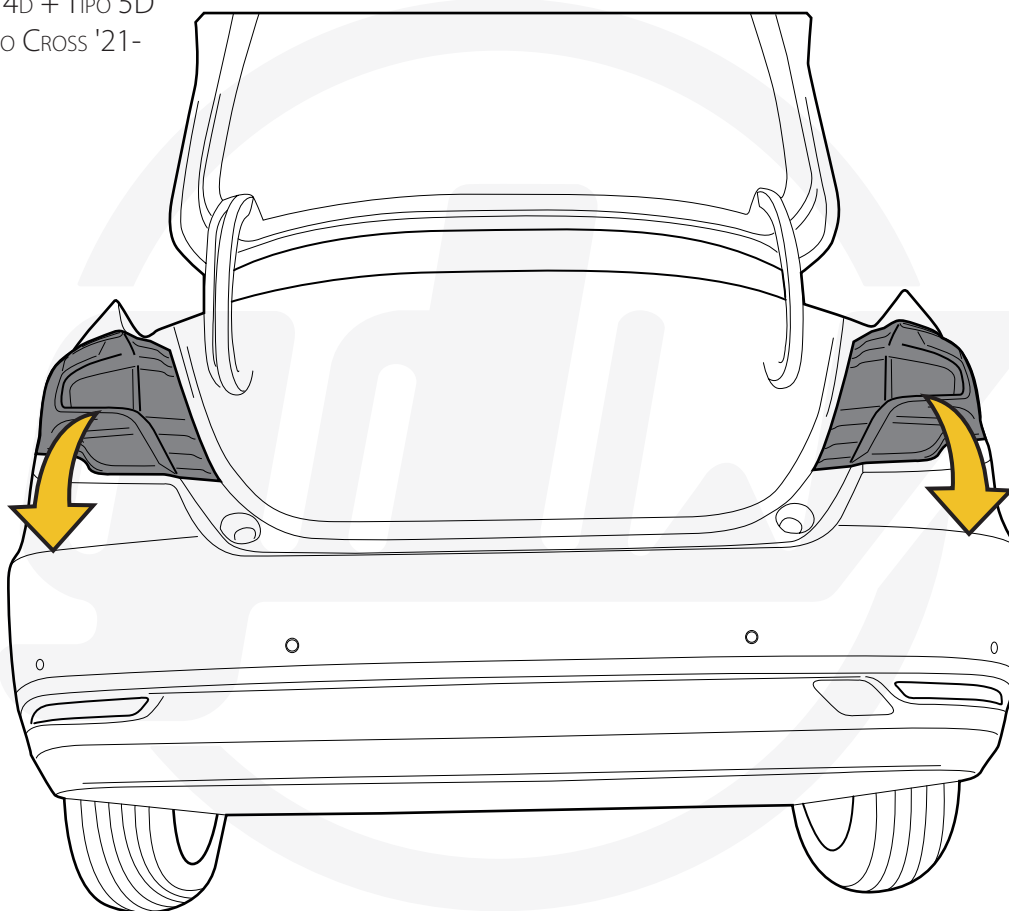

20 FIAT TIPO 4D + TIPO 5D  
+FIAT TIPO CROSS '21-

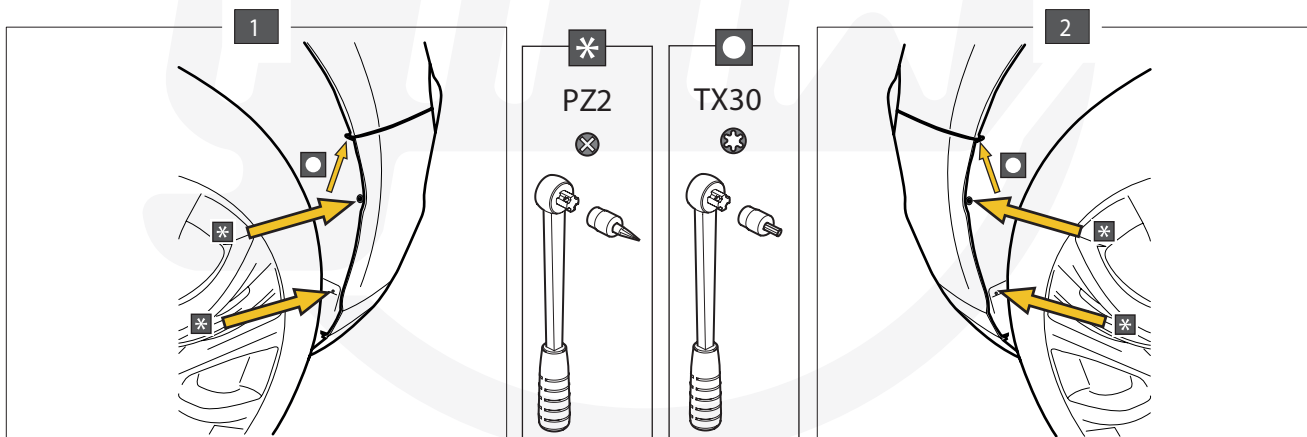
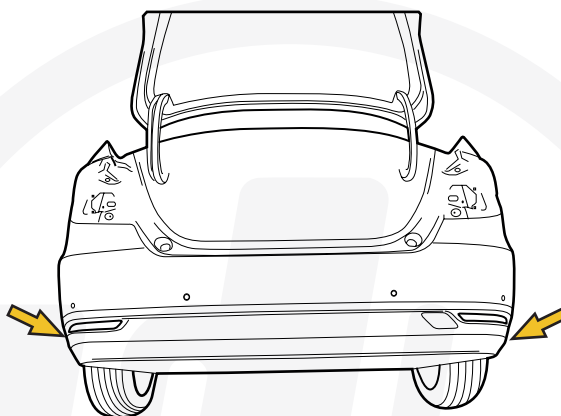

21 FIAT TIPO 4D + TIPO 5D  
+FIAT TIPO CROSS '21-

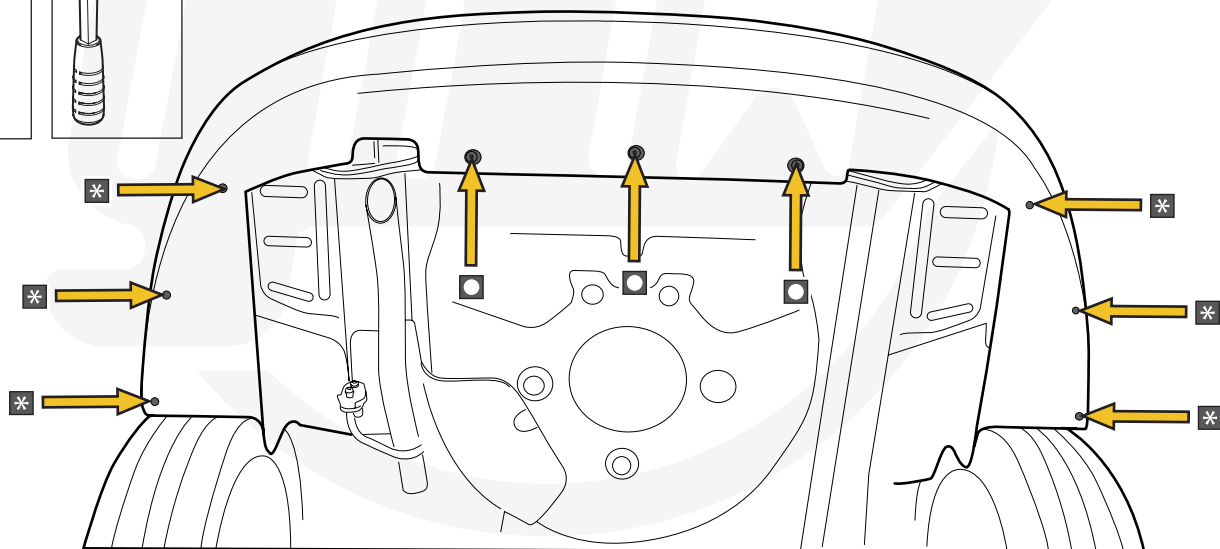
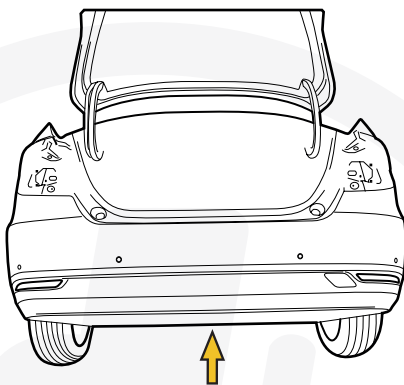
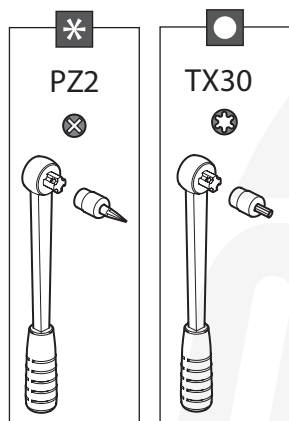

22 FIAT TIPO 4D + TIPO 5D  
+FIAT TIPO CROSS '21-

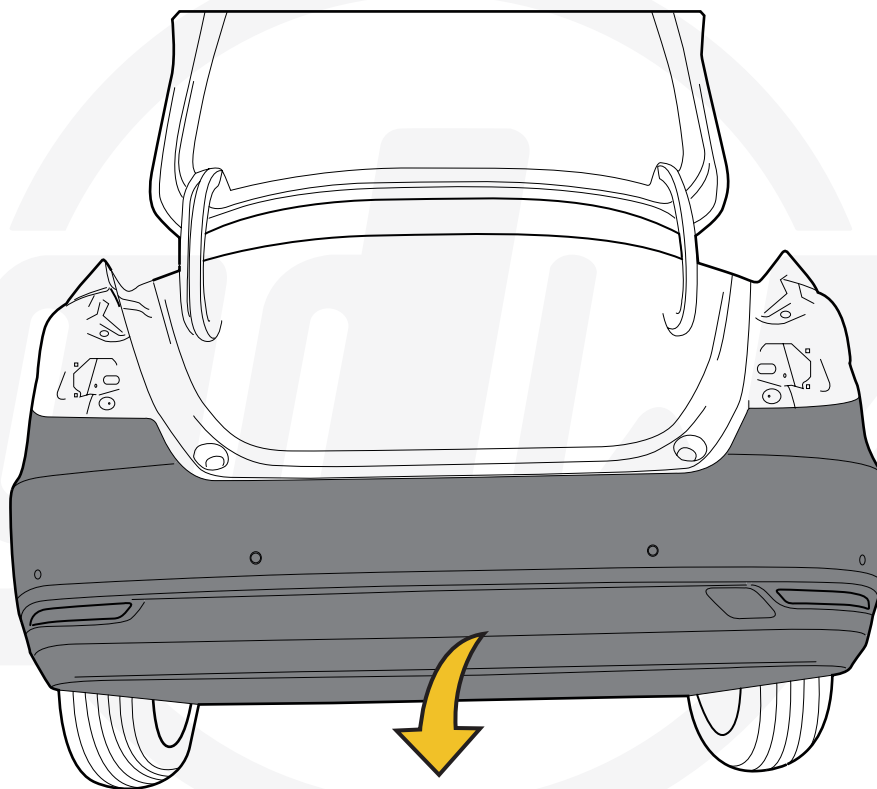

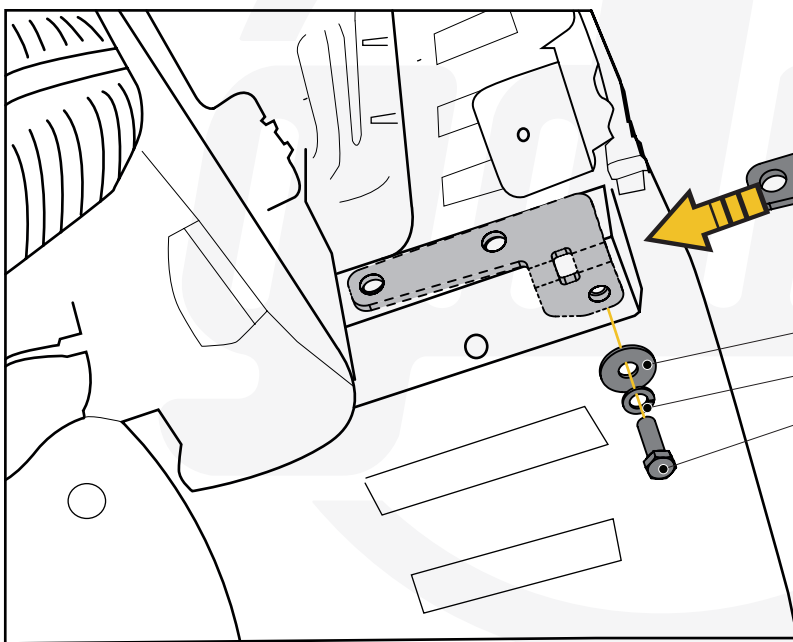
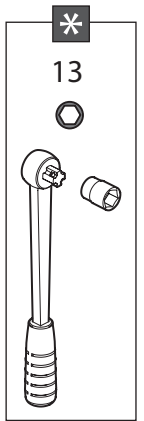
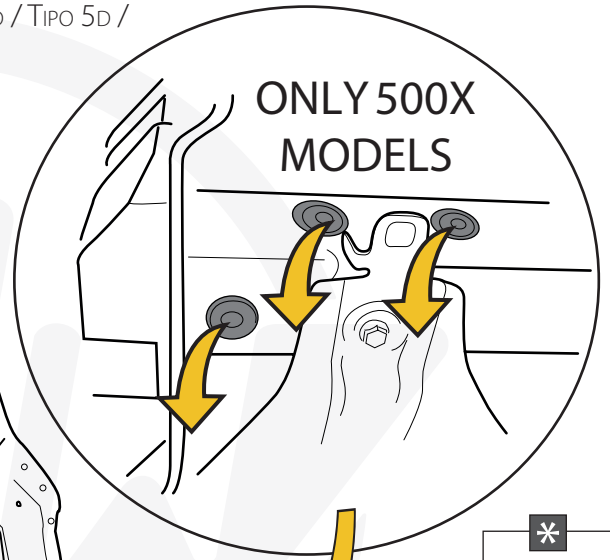
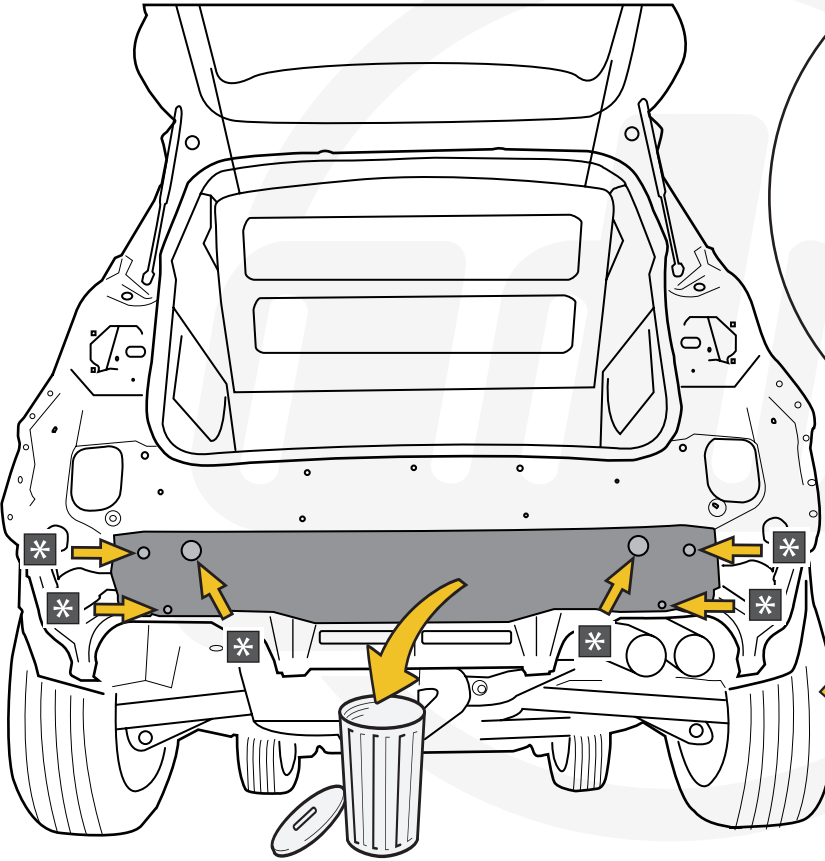

- 16
- 17
- 15 \*

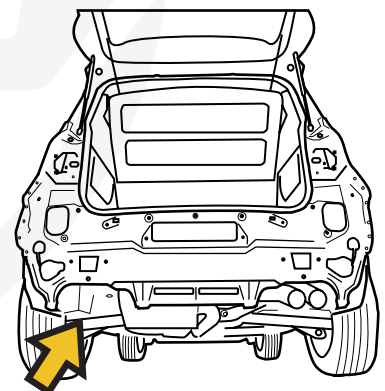
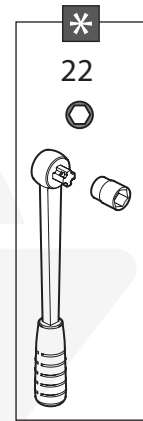

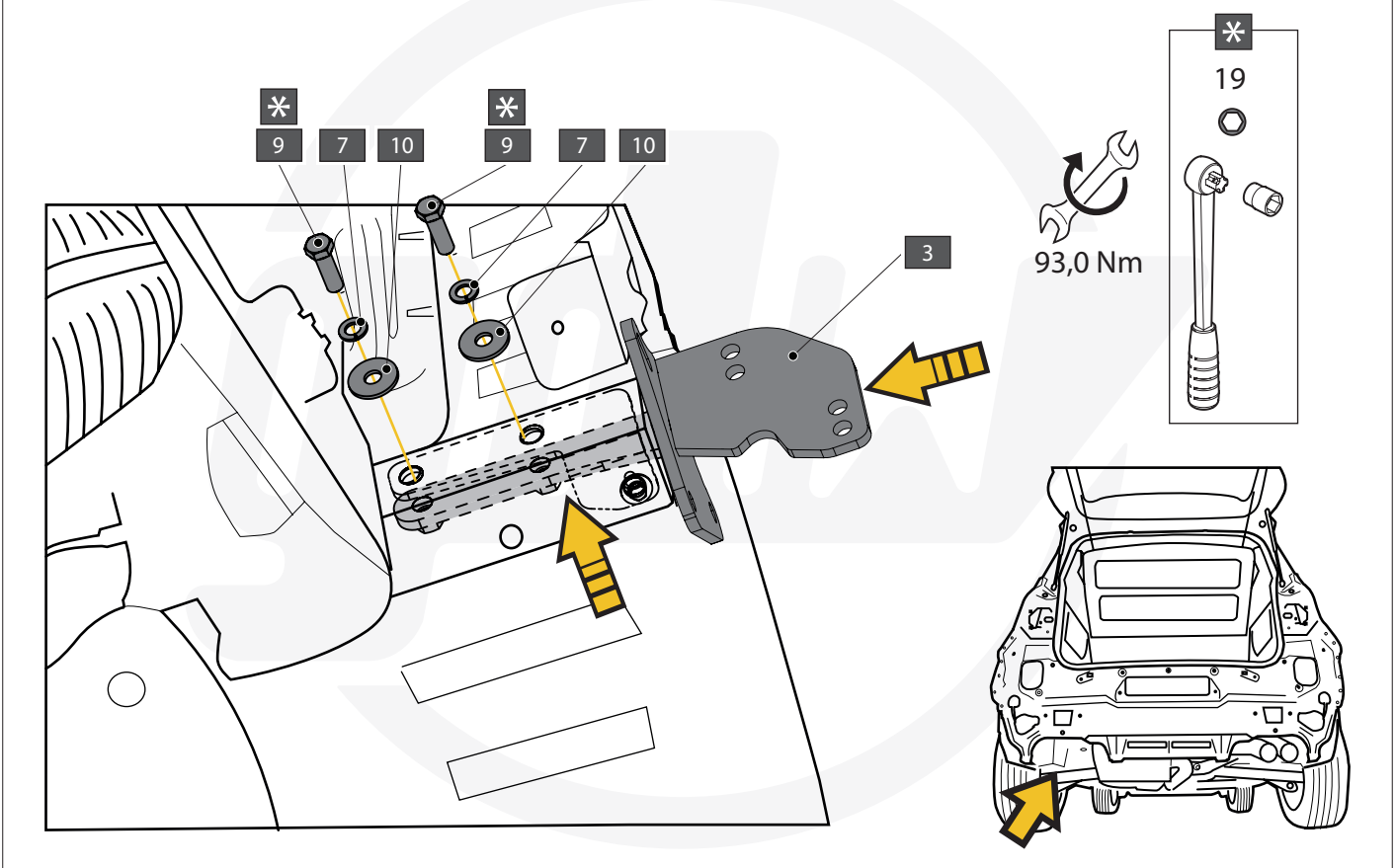
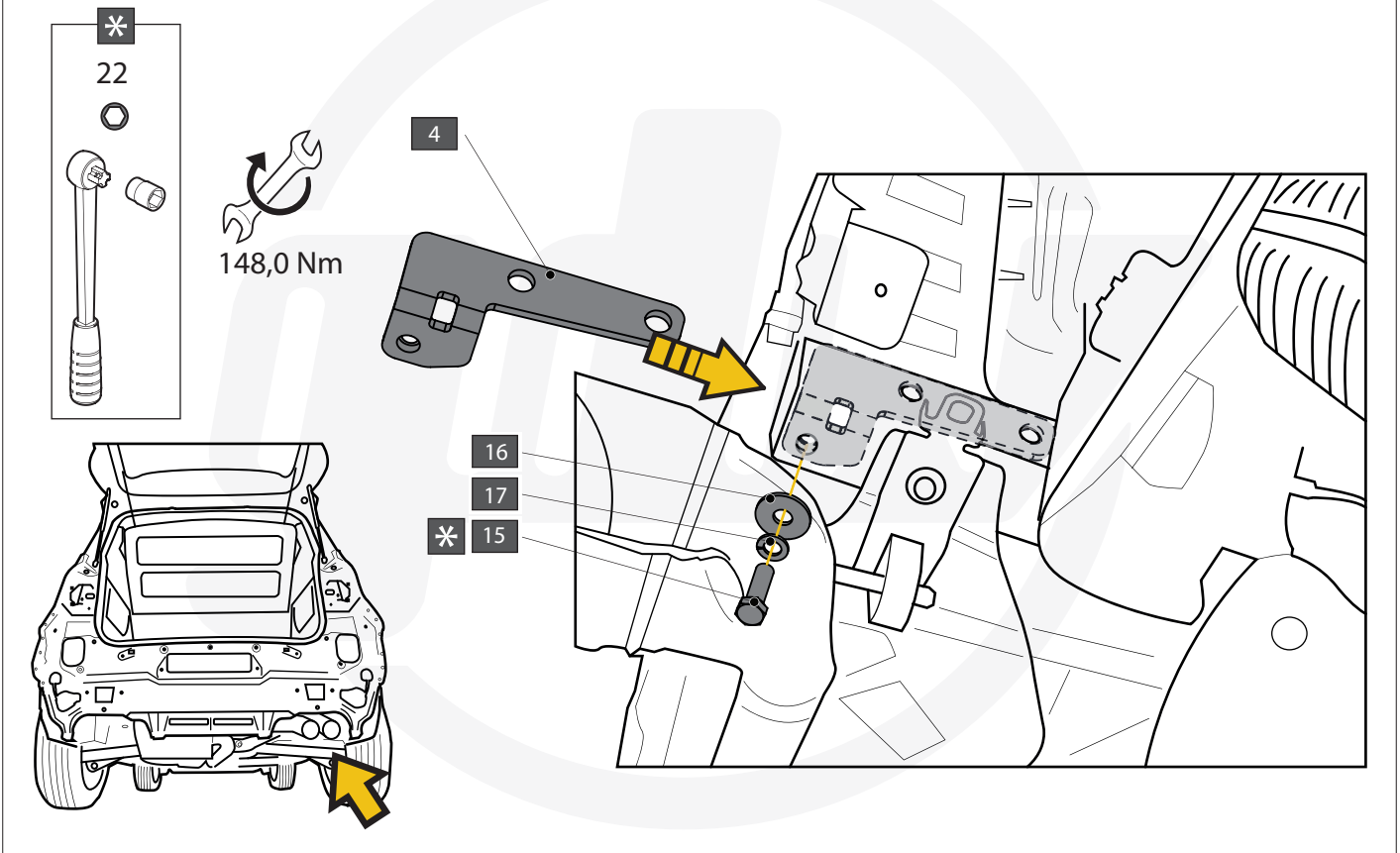

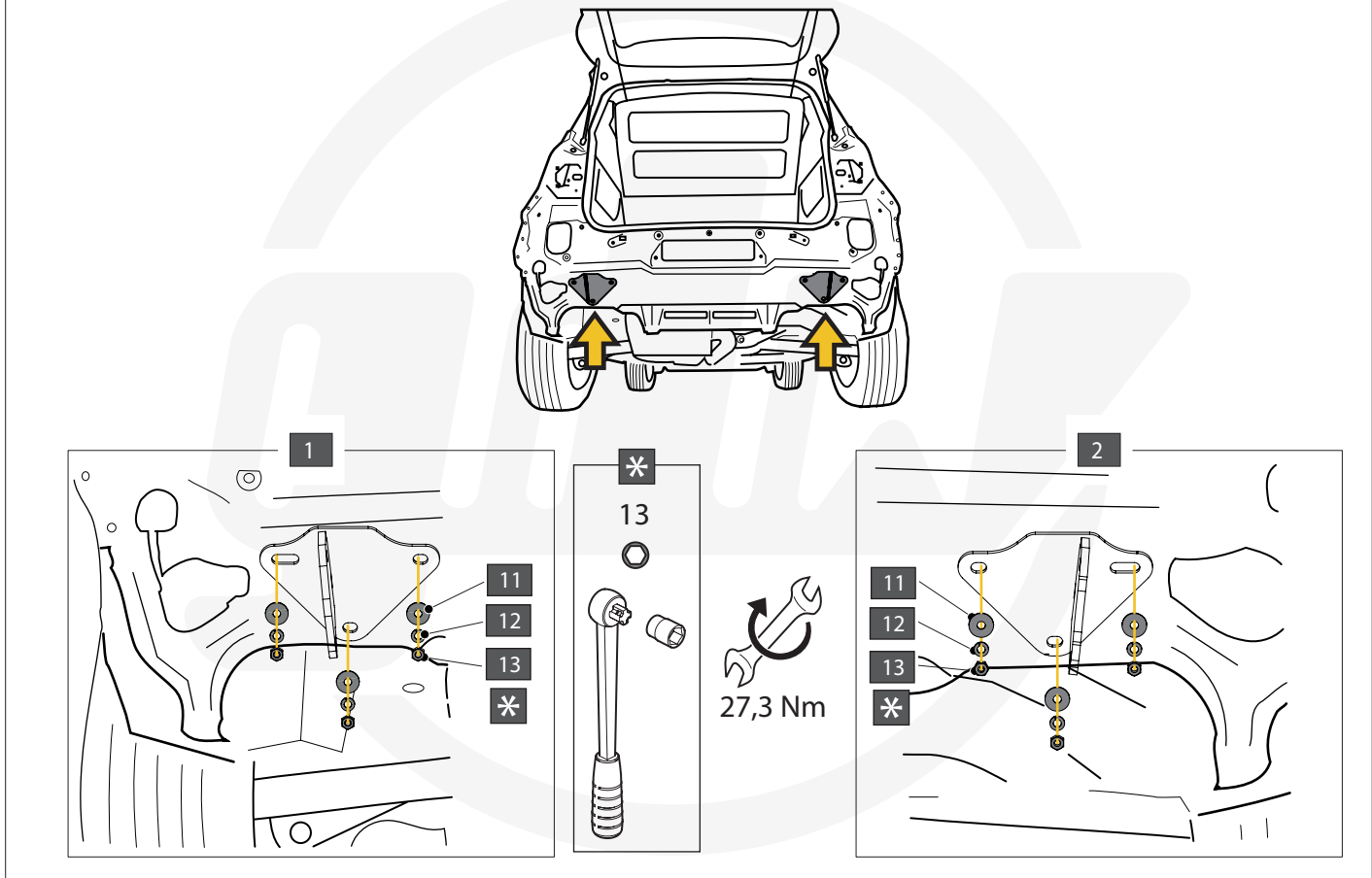
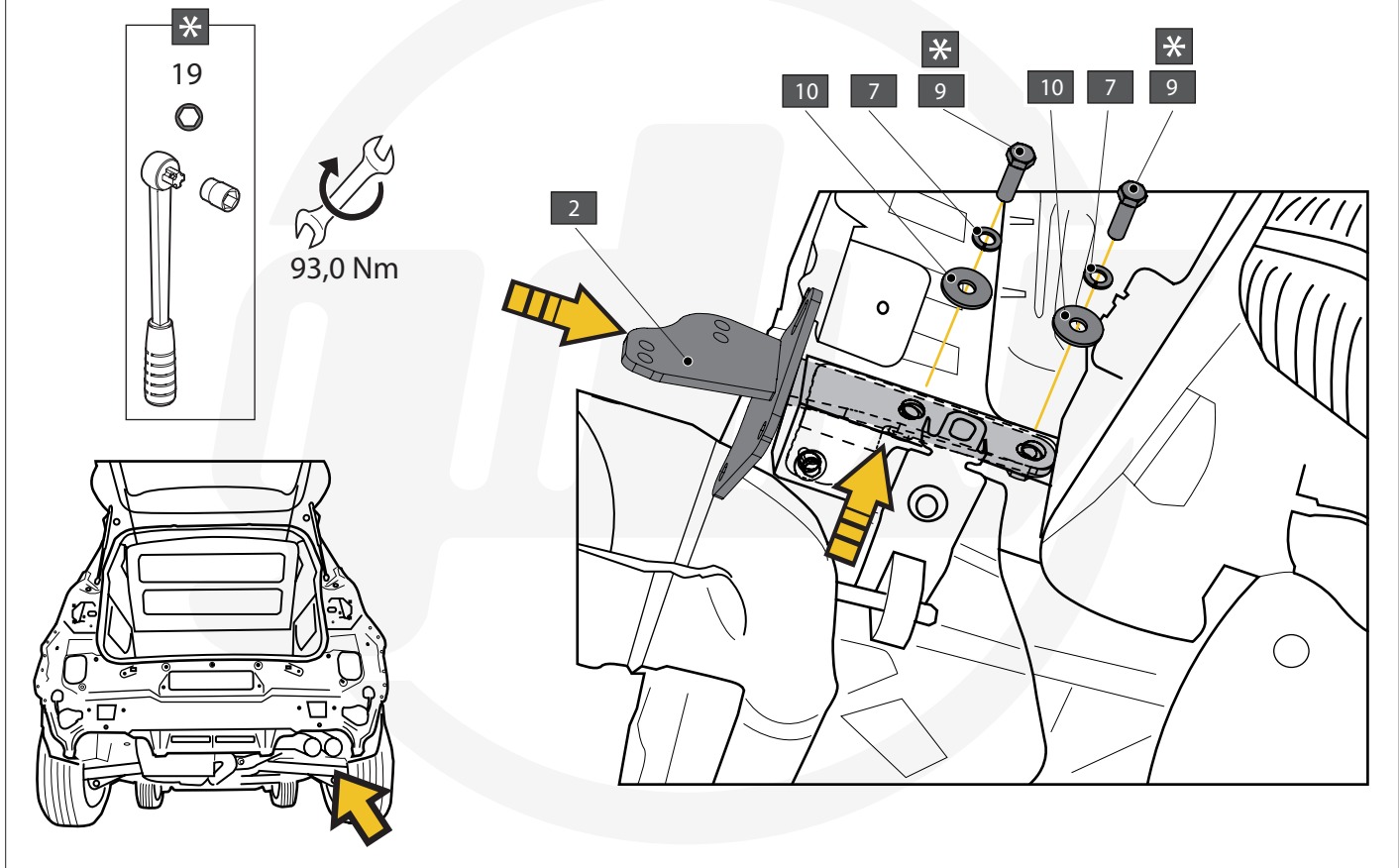

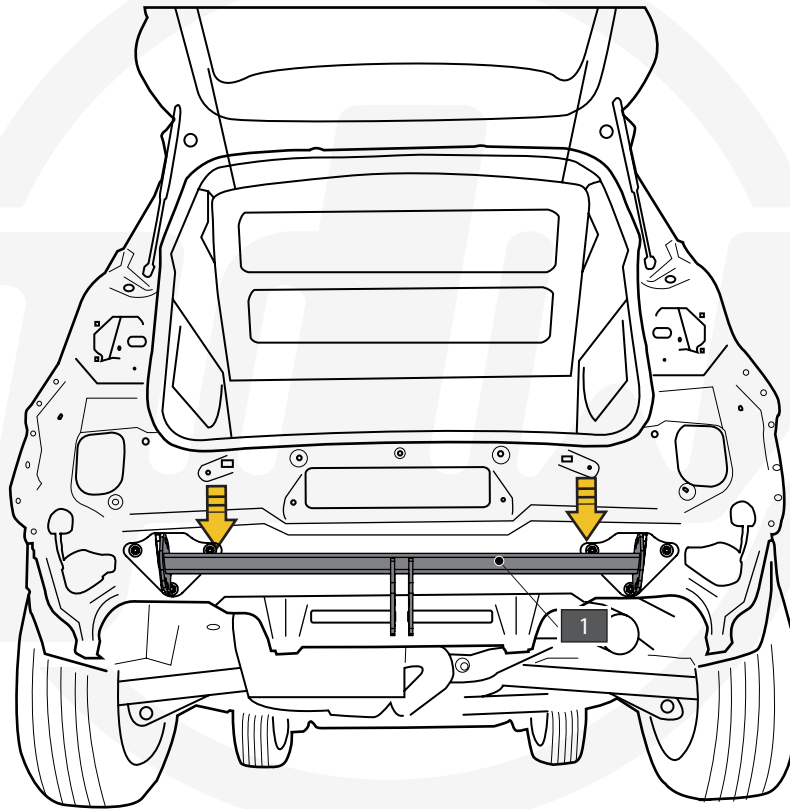

Jeep Renegade & Fiat 500 + 500X-Cross '15 - '18

Fiat Tipo 4D + Tipo 5D

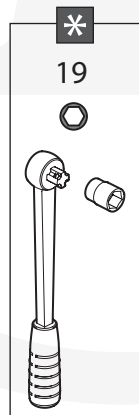
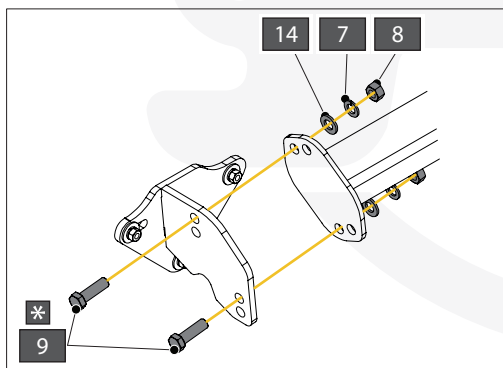
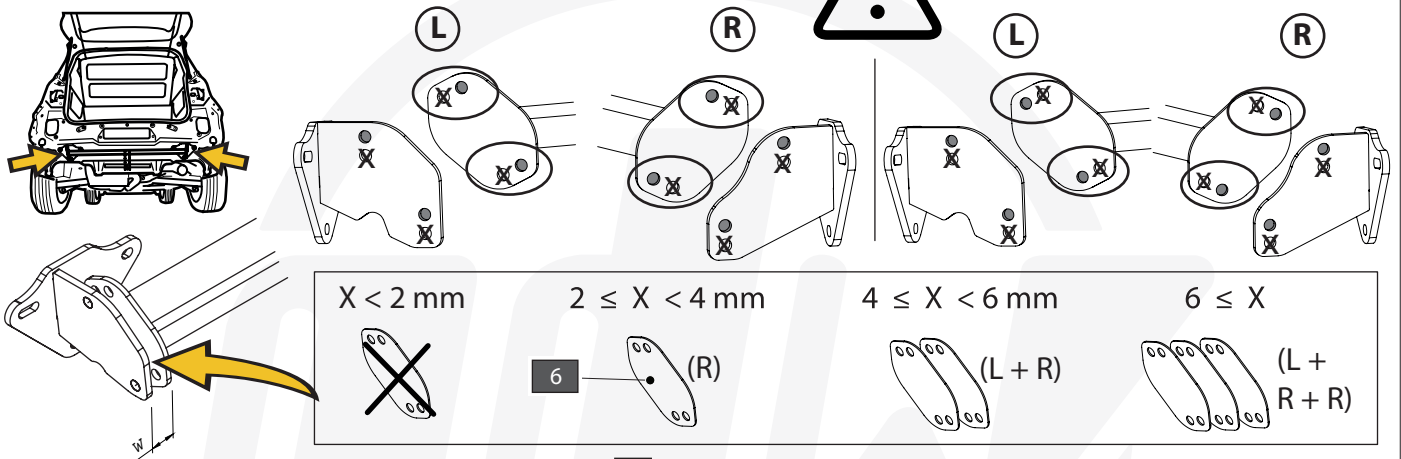

93,0 Nm

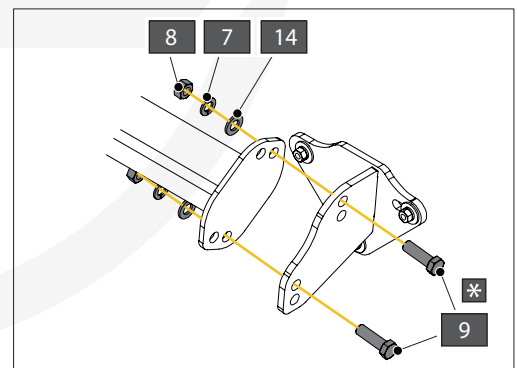

Fiat Tipo Cross

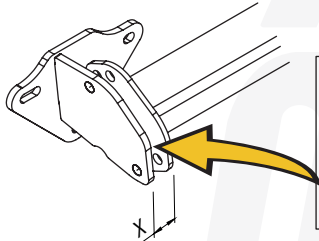
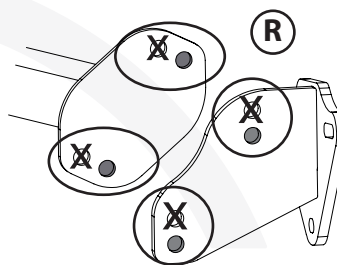
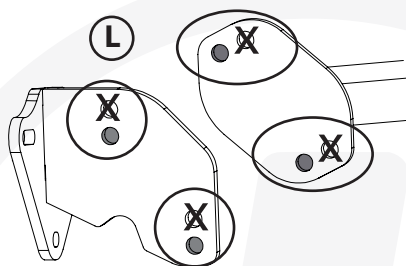
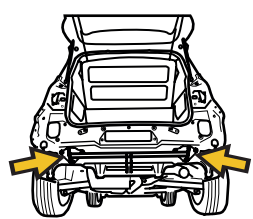

$X < 2 \text{ mm}$	$2 \leq X < 4 \text{ mm}$	$4 \leq X < 6 \text{ mm}$	$6 \leq X$

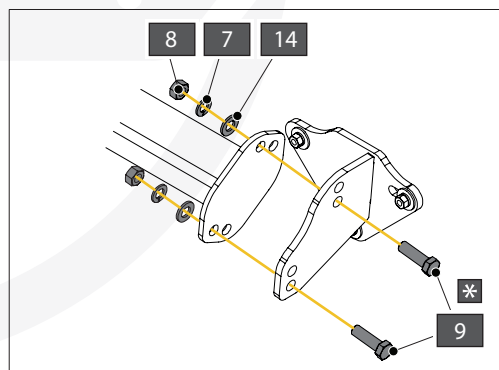
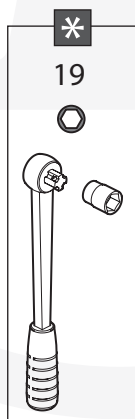
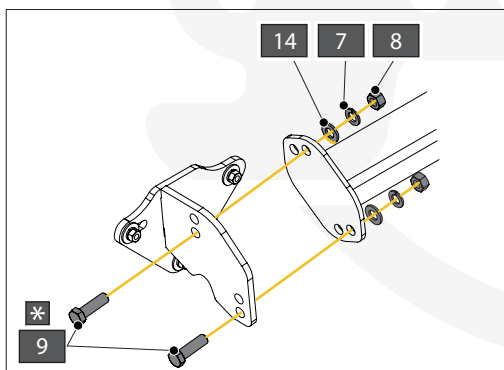

Fiat 500X Sport + Fiat 500X Urban + Fiat 500X Cross Facelift '19 -

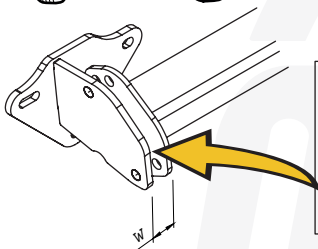
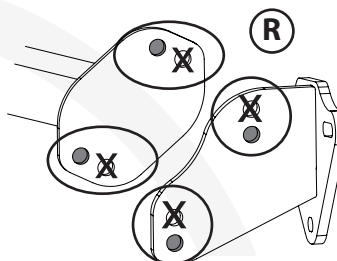
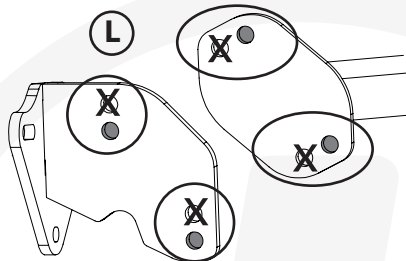
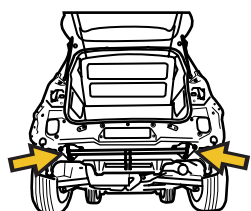

$X < 2 \text{ mm}$	$2 \leq X < 4 \text{ mm}$	$4 \leq X < 6 \text{ mm}$	$6 \leq X$

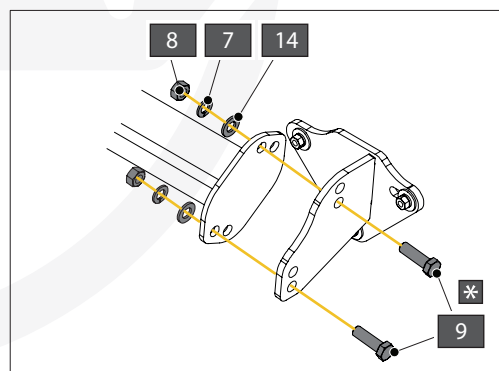
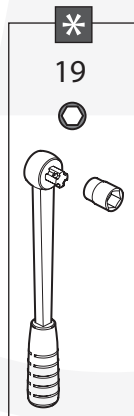
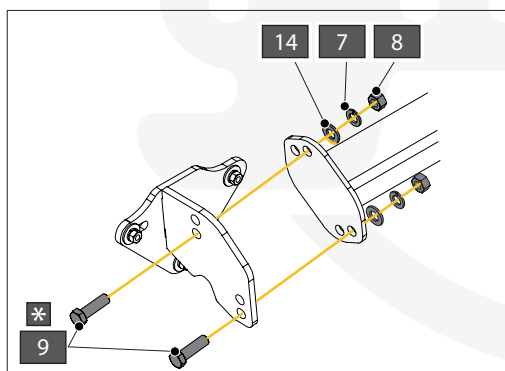

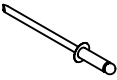
\*  x7 DIN7337 4,8x16

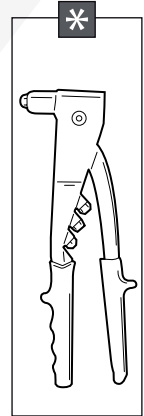
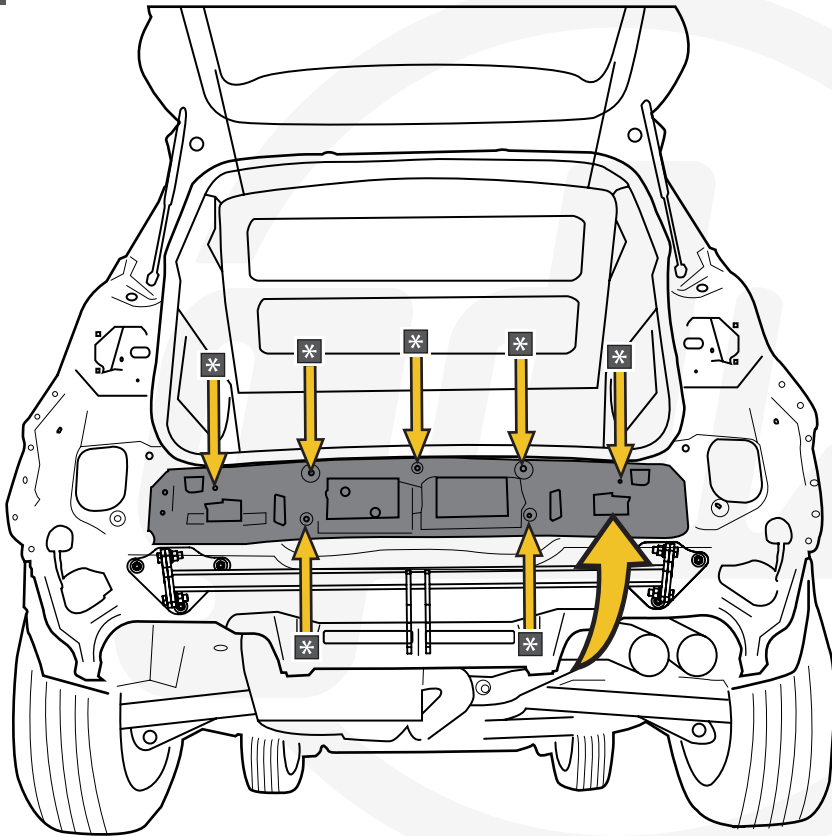

T48

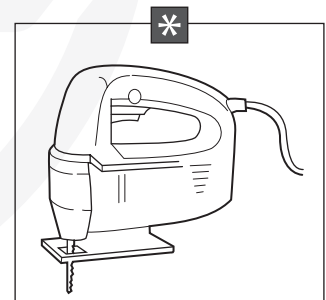
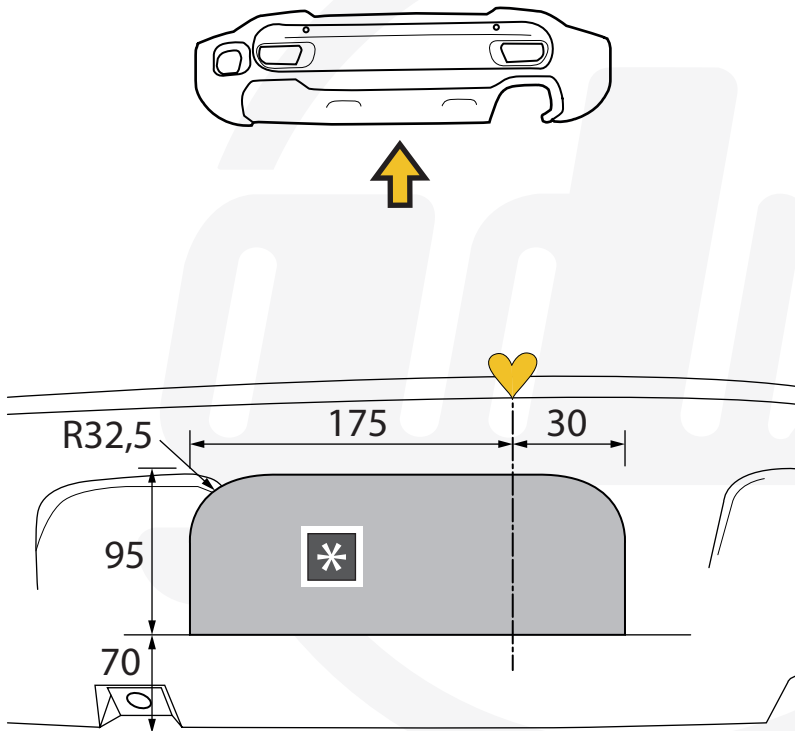
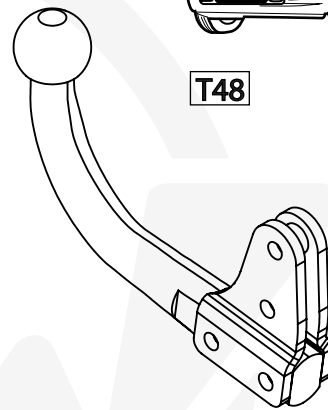

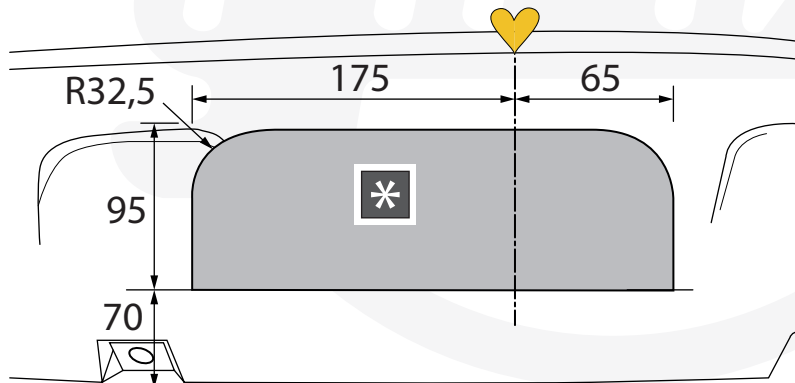
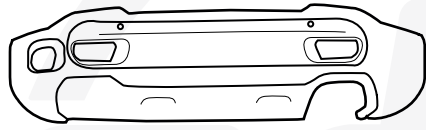

T38

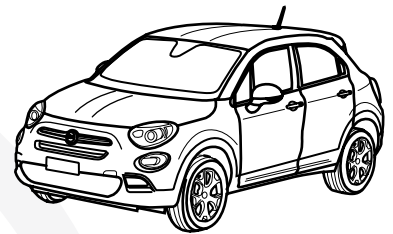
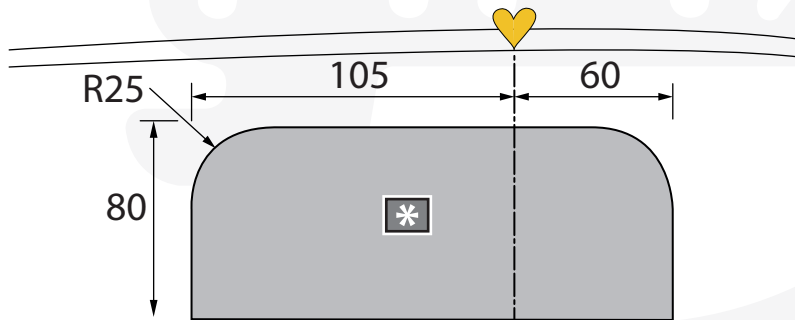
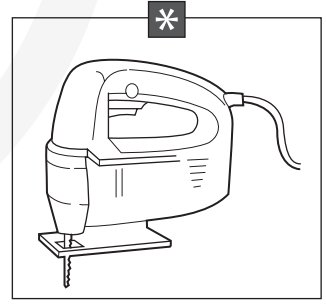
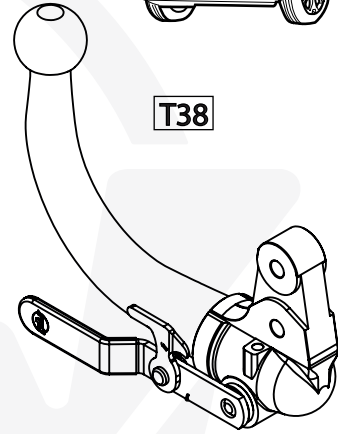

T48

T38

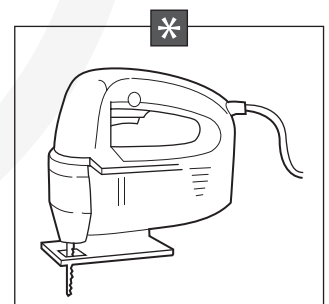
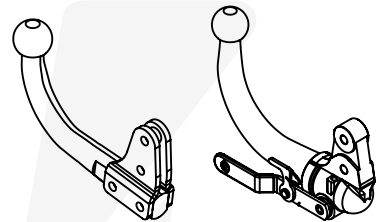



T48

T38

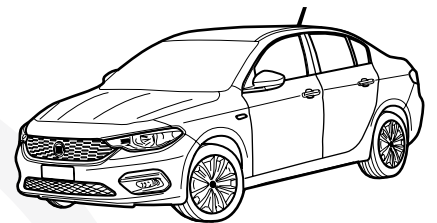
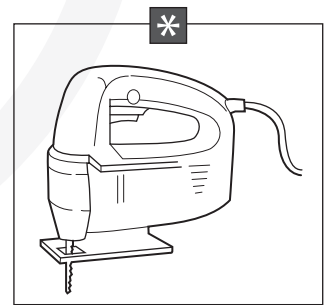
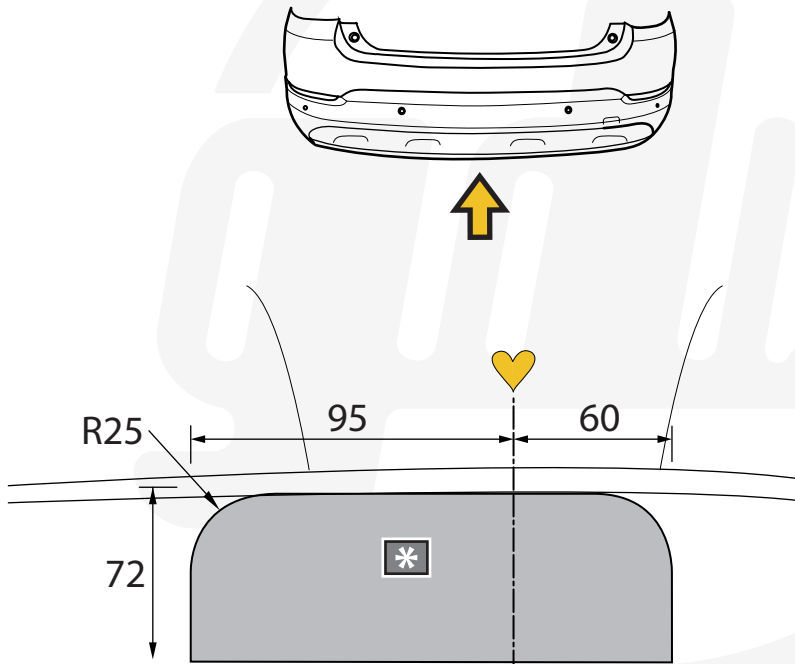
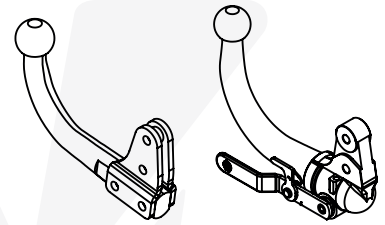

T48

T38

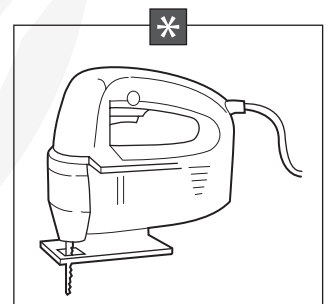
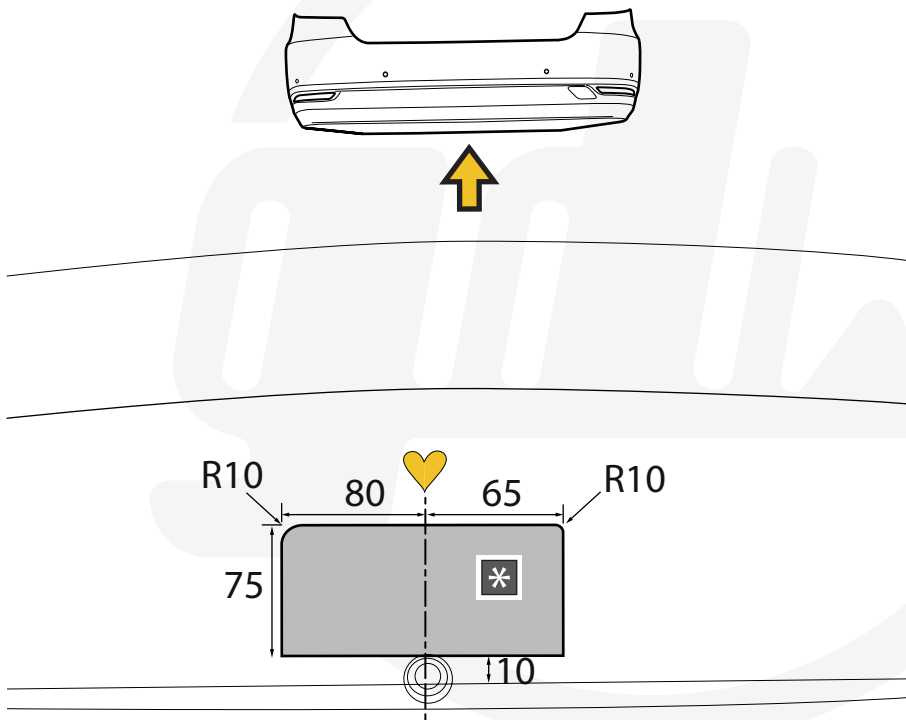
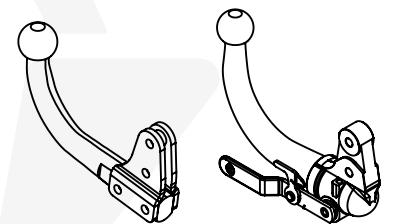

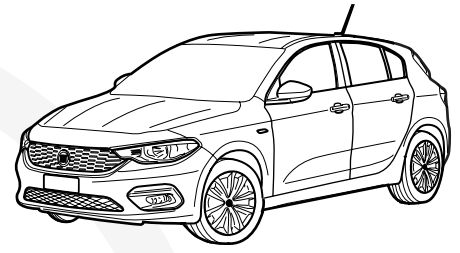
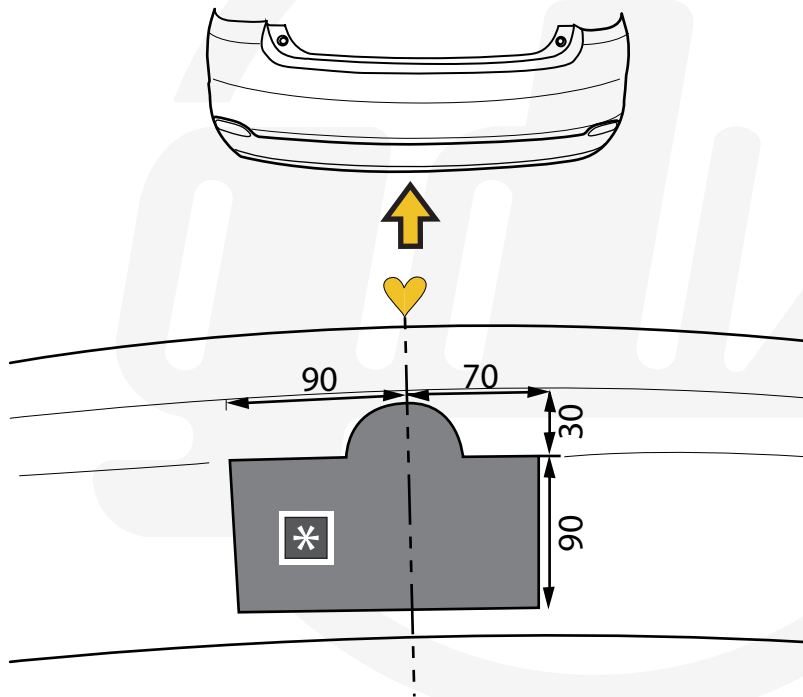

T48

T38

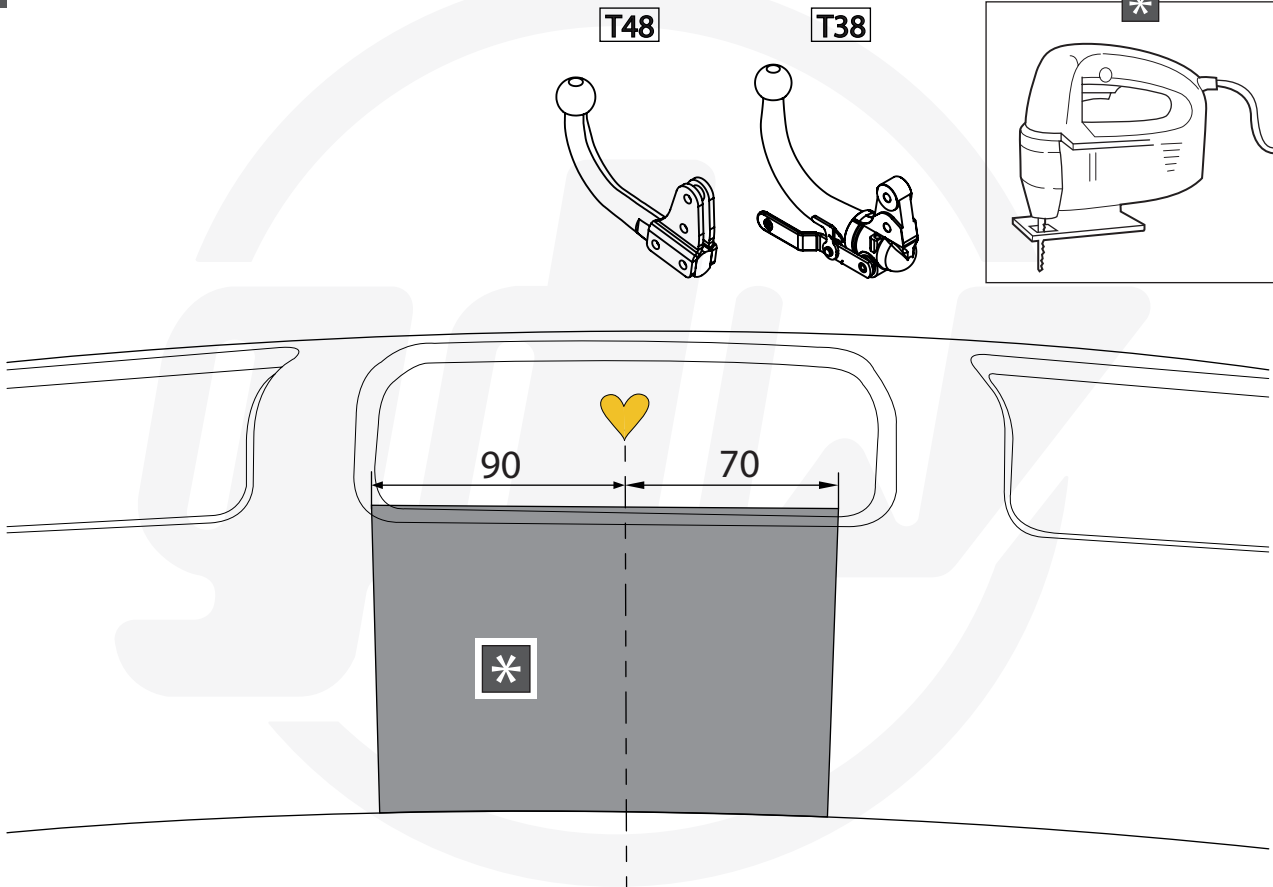
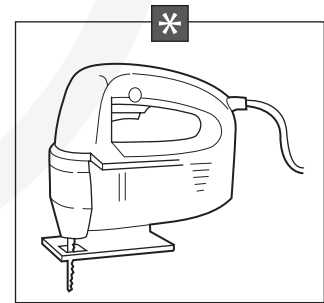
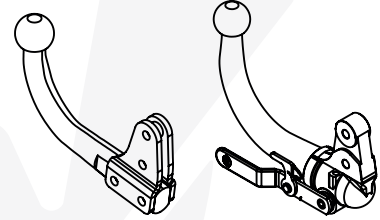

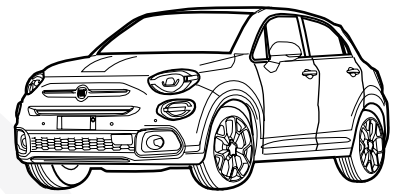
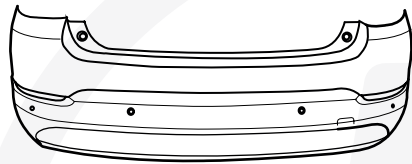

T48

T38

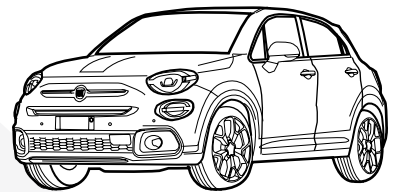
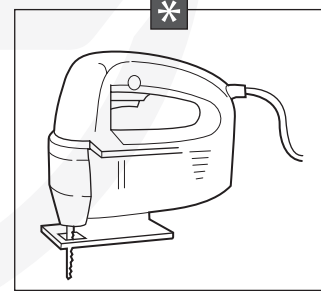
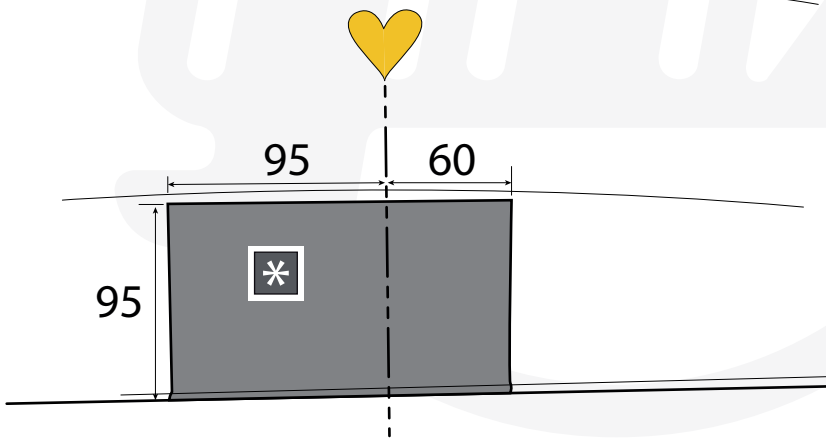
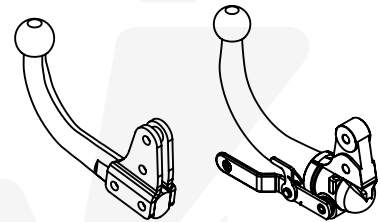

T48

T38

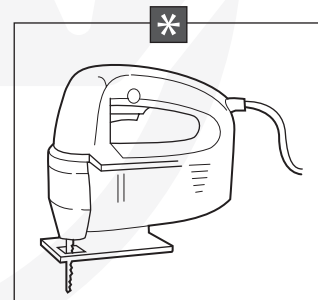
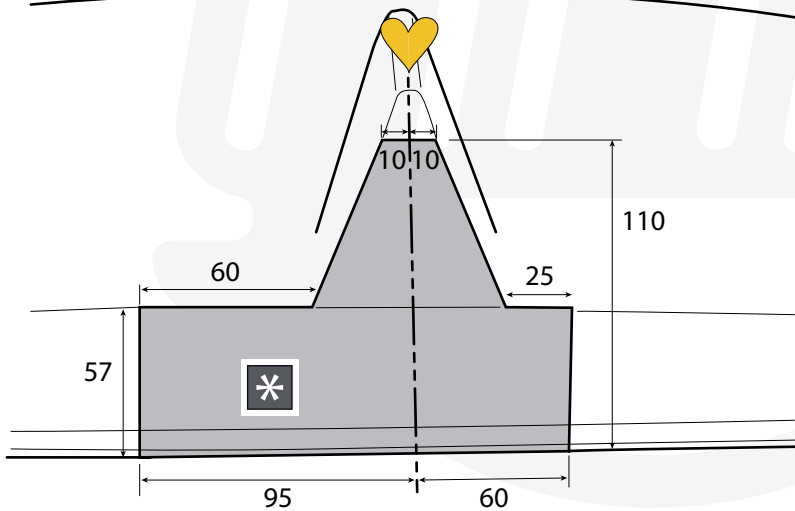
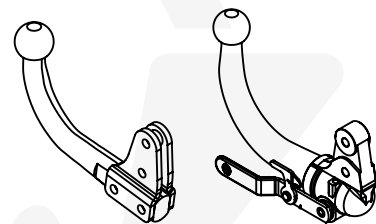

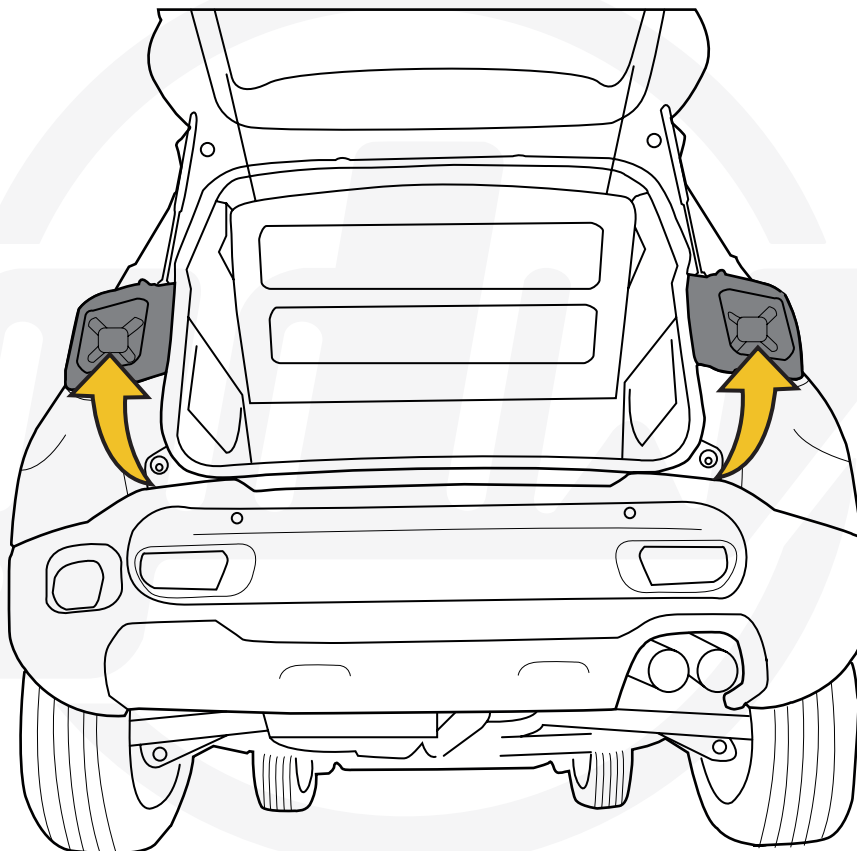
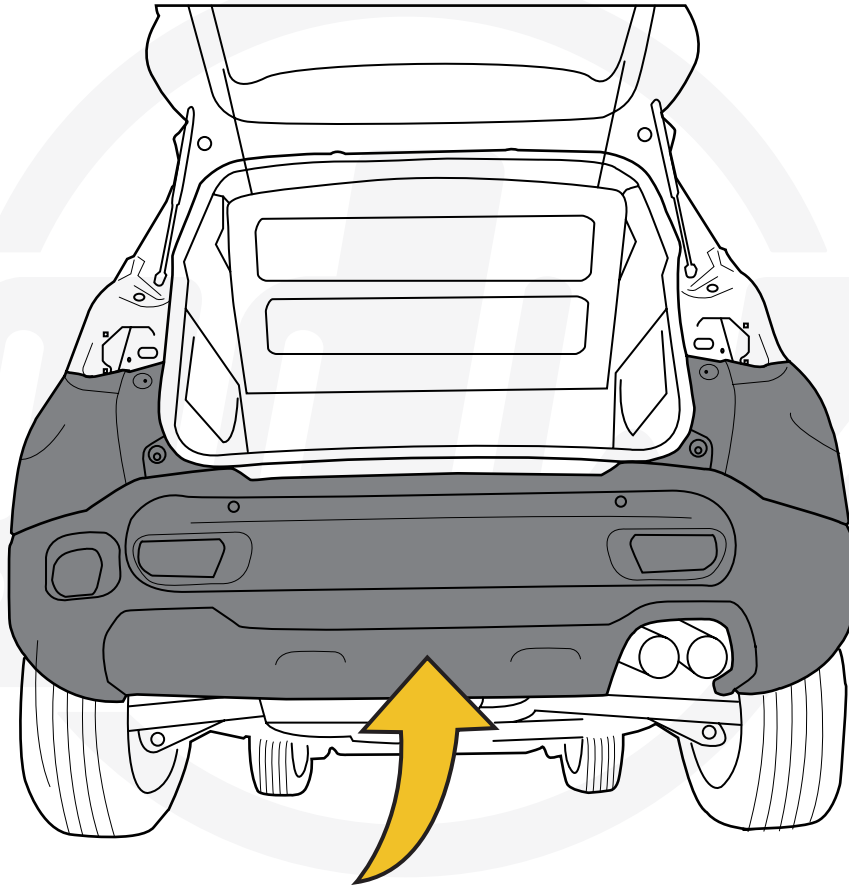

45 JEEP RENEGADE

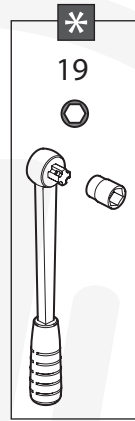
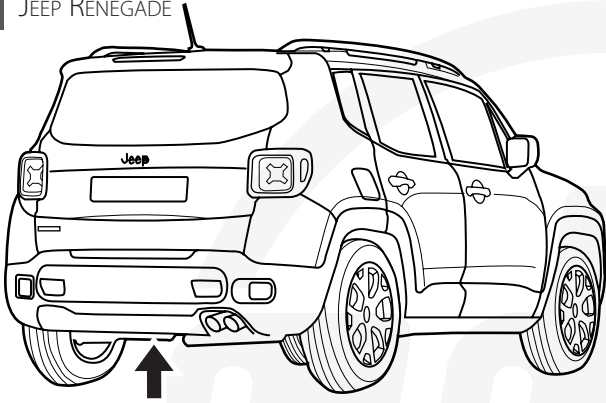

93,0 Nm

-P		X1	GDW REF. P07
B		X1	GDW REF. 900.025
C		X1	GDW REF. 900.026
D		X2	GDW REF. 900.011
E		X2	DIN931 M12 X 70
F		X2	DIN985 M12

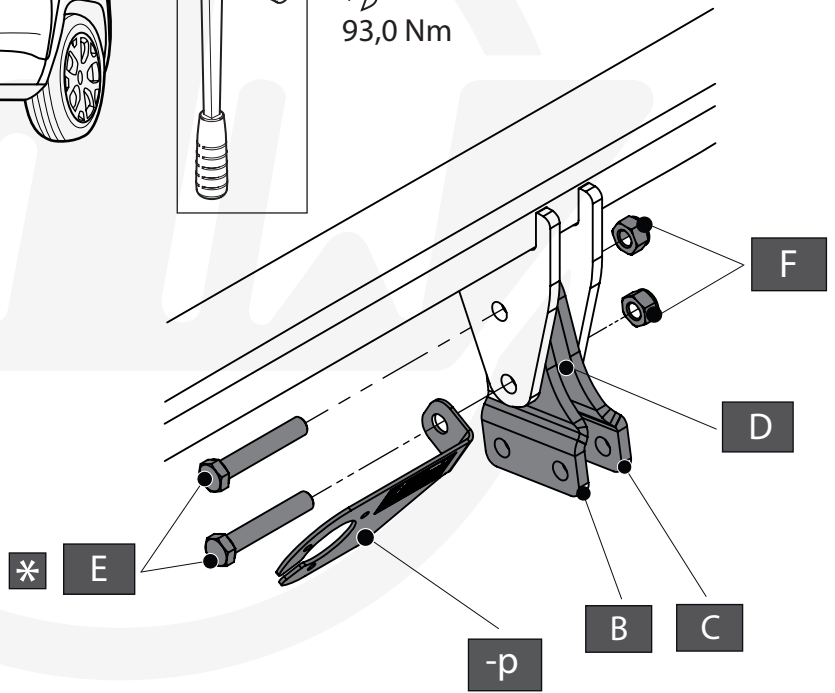

46 JEEP RENEGADE

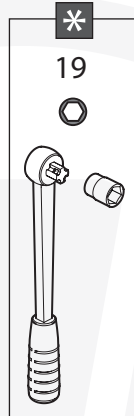
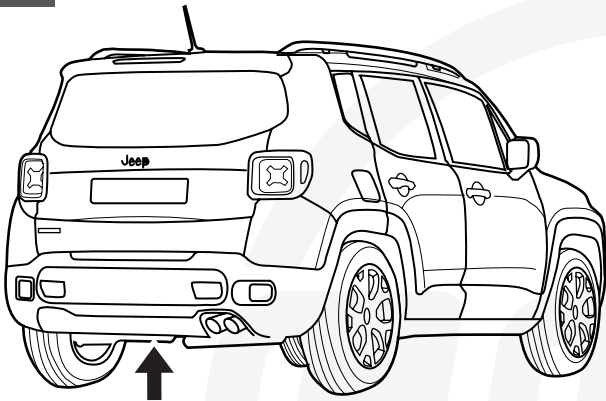

93,0 Nm

A		X1	944.H019
-S		X1	GDW REF. 900.053
E		X2	DIN931 M12 X 70
F		X2	DIN985 M12

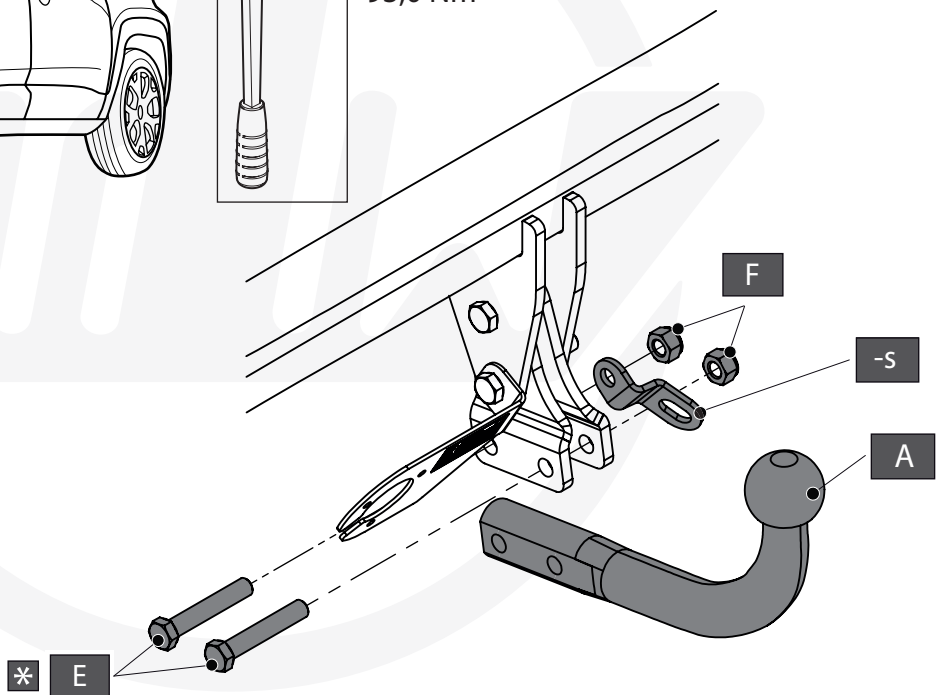

47 FIAT 500X / 500X-CROSS + FACELIFT / TIPO 4D + TIPO 5D /  
TIPO CROSS /500X URBAN / 500X SPORT

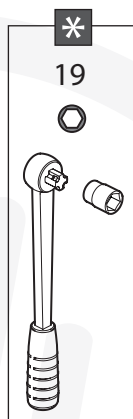
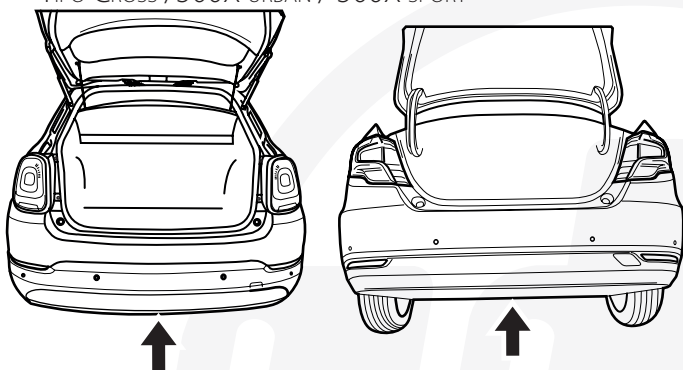

93,0 Nm

-P		X1	GDW REF. PO4
B		X1	GDW REF. 900.025
C		X1	GDW REF. 900.026
D		X2	GDW REF. 900.011
E		X2	DIN931 M12 X 70
F		X2	DIN985 M12

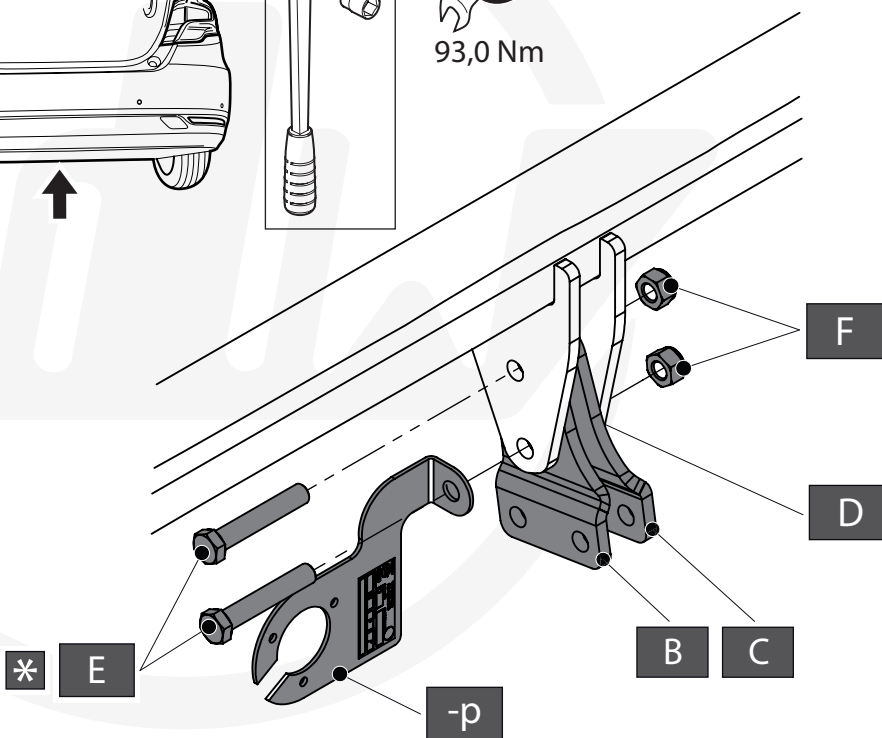

48 FIAT 500X / 500X-CROSS + FACELIFT / TIPO 4D + TIPO 5D /  
TIPO CROSS /500X URBAN / 500X SPORT

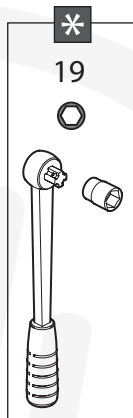
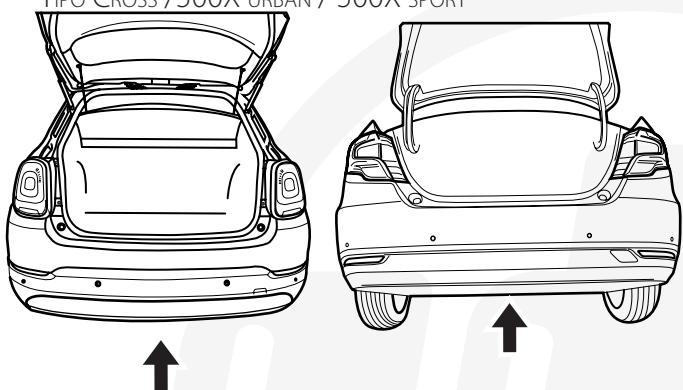

93,0 Nm

A		X1	944.H019
-S		X1	GDW REF. 900.053
E		X2	DIN931 M12 X 70
F		X2	DIN985 M12

